

# Alfa Laval S 928–S 988

## Cleaning systems for heavy fuel oils (as well as lighter fuel oils and lubricating oils)

### Introduction

Alfa Laval's S Flex separation systems combine the high efficiency, low sludge output and low operating cost of Alfa Laval centrifugal separators with a flexible scope of supply. Extensive possibilities for the separation system layout and assembly make it possible to suit any engine room and any oil separation application.

In addition, S Flex separation systems feature the EPC 60 controller, which enables the easy navigation of menus, parameters and alarms. The EPC 60 controller also has a modular construction for easy I/O board addition and replacement.

The S Flex separation concept includes the complete S separator range. Separators of different sizes can be combined into one module, including both fuel and lube cleaning, even within a single customer specified module.

### Application

S separators are based on Alcap technology, which means they detect when the oil/water interphase moves into the disc stack and automatically activates the drain or discharge mechanism and thereby maintain best possible performance at all times. This makes them particularly suitable for separating fuels and oils with varying density and viscosity, though they can be used to clean all of the following:

- Residual fuels
- Distillate fuels
- Biofuels
- Lubricating oils

S separators efficiently clean distillate and residual fuels according to ISO 8217, including ultra-low, very-low and high sulphur fuel oils (ULSFO, VLSFO and HSFO) with densities up to 1 010 kg/m<sup>3</sup> at 15°C and viscosities up to 700 cSt at 50°C.

The S separator is optimized to clean biofuels according to EN15940 (HVO) and EN14214/ASTM D6751 (FAME). For treatment of other fuel types please consult your local Alfa Laval office.

S separators are designed for automatic operation in periodically unmanned engine rooms at sea and in power stations ashore.



### Benefits

- *Small footprint, high flexibility* — The small separator and the modular nature of the surrounding components allow easy installation and flexible positioning in the engine room.
- *Alcap technology* — A water transducer in the clean oil outlet automatically adjusts the oil/water interphase to maximize separation performance.
- *Maximum separation efficiency* — An optimized design ensures the best possible separation efficiency from the bowl and disc stack.
- *CentriShoot* — The CentriShoot discharge system greatly reduces sludge volumes. Its fixed discharge slide flexes gently to expose the discharge ports, thereby eliminating metal-to-metal wear.

- *CentriLock* — The CentriLock bowl-locking system uses a lightweight, non-threaded snap ring. This prevents wear by allowing easy removal without a sledgehammer.
  - *Long service intervals* — Wear-preventing features like CentriShoot and CentriLock reduce the consumption of spare parts and allow planned maintenance to be performed less often. This reduces operating costs.
  - *Certified Separation Performance.* — The S separators 928–988 are tested and certified according to the CFR standard test established in the CEN Workshop Agreement CWA 15375.
  - *Easy operation and service* — The PLC based EPC 60 controller is designed for "one-button" starts and stops, as well as easy menu navigation. Information about parameters and alarms can be easily accessed, which simplifies both operation and troubleshooting. The EPC 60 also has a modular construction that enables faster troubleshooting and I/O board replacement.
- Remote control and monitoring* — Using Ethernet or Bus communication, Flex systems and modules based on S separators 928–988 can be operated and supervised remotely from the control room. A variety of alarm functions are available as standard, and extra I/O boards can be added to the EPC 60 controller in order to enhance its operating and monitoring capabilities.

## Design



1



2

1. **Single Flex module** with separator, heater and pump
2. **Quadruple Flex module** with separators, heaters and pumps

The S Flex separation concept provides a wide range of alternatives for S separators. Depending on the need, an S separator can be supplied as a separator and ancillaries, as a customer-specified module, or as part of a comprehensive package including services and order-specific documentation. These S separators come equipped with energy-efficient IE3 motors.

## Flex system

An S separator with ancillaries in the form of optimized block components provides full say over the use of space. This allows for local modularization or do-it-yourself assembly.

## Flex modules

A compact S separator module can be built to a customer-specified configuration from a wide range of modular skirts and machine blocks. Multi-modules are possible, as well as mixed modules including one or more S separators and/or P separators for the simultaneous treatment of different types of mineral oils. All Flex modules are factory tested to ensure faster start-up and commissioning.

## Scope of supply

The S and P Flex separation concept provides a wide range of alternatives for S-separators. Depending on the need, a S-separator can be supplied as a separator and ancillaries, as a customer-specified module, or as part of a comprehensive package including services and order specific documentation

## Options

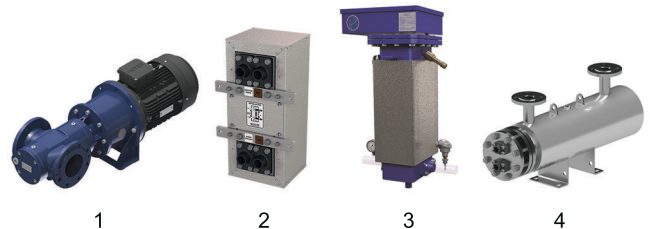

1. ALP feed pump with IE3 motor
2. HEATPAC CBM heater
3. HEATPAC EHM heater
4. S&T Heat exchanger

Flex separation systems based on S separators 928–988 can be complemented with the following equipment:

- Starter (included in module versions)
- HEATPAC heaters
- Space heating
- Additional thermometers
- Vibration sensor kit
- ALP feed pump
- Flow regulating system
- Sludge removal kit
- Sludge outlet butterfly valve kit
- Steam shut-off valve kit
- Air pressure reducer valve
- Pipe arrangement for multiple modules, including heater cross-connection
- Emergency safety shutdown
- Remote monitoring and control
- Separator lifting tool

## Working principle

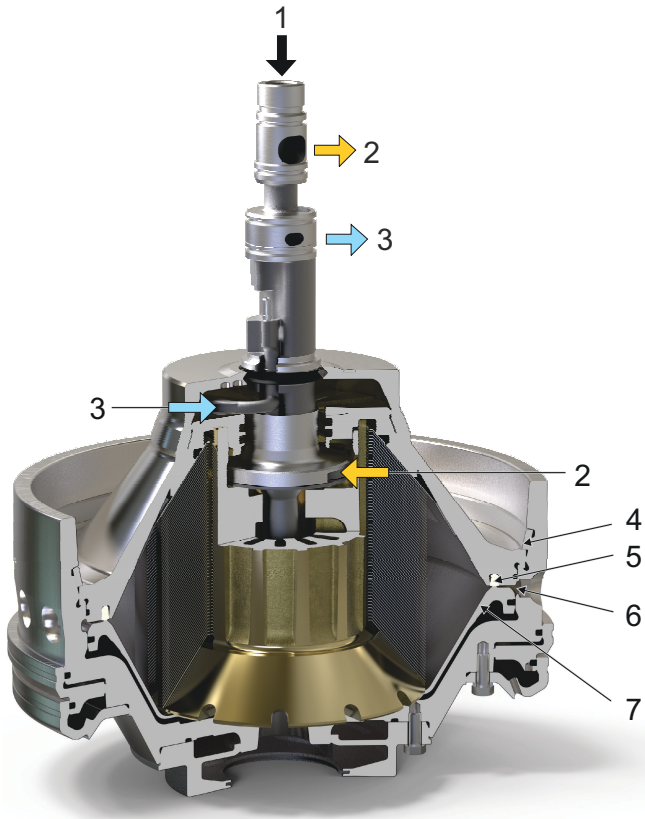

1. Untreated oil
2. Clean oil
3. Water
4. CentriLock
5. Seal ring
6. Discharge port
7. Discharge slide

A Flex separation system based on an S separator 928–988 is operated automatically by the EPC 60 controller. Untreated oil, heated to the correct temperature, is fed continuously to the separator, which is driven by an electric motor via a friction clutch and belt.

The separator bowl is fixed at the top of a spindle, which is supported by bearings and special composite springs. During operation, separated sludge and water accumulate at the bowl periphery and are intermittently discharged by the high-precision CentriShoot discharge system.

The separator's operation is based on the Alcap principle, which means the separator automatically adjusts to the nature of the oil. No gravity disc is needed. A water transducer in the clean oil outlet measures capacitance, in picoFarads, and signals changes to the EPC 60 controller.

Depending on the water content, the EPC 60 either opens the drain valve or expels the water through the bowl discharge ports during sludge discharge. A patented paring tube adapts itself to remove the water from the bowl while a paring disc pumps away the clean oil.

During normal operation, vital process parameters are monitored. These parameters, as well as alarms, are indicated by easy-to-understand text messages on the LCD display of the EPC 60 controller.

The EPC 60 controller provides many alarm functions, including alarms for low oil pressure, high sludge tank level (if the optional sludge removal kit is included) and power failure. Additional functions are available for a vibration alarm when the optional vibration sensor is fitted.

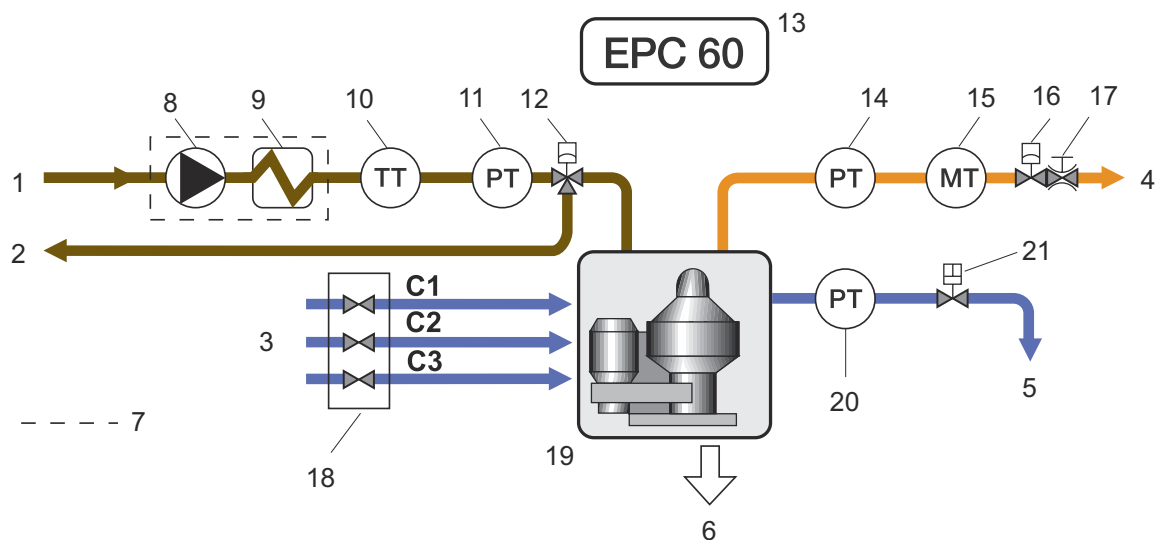

1. Untreated oil inlet
2. Oil return
3. Water inlet (C1 = Conditioning water, C2 = Opening water, C3 = Closing water)
4. Clean oil outlet
5. Water outlet
6. Sludge outlet
7. Optional
8. Feed pump
9. Heater
10. Temperature transmitter
11. Pressure transmitter, oil
12. Pneumatically controlled change-over valve
13. Control unit
14. Pressure transmitter, oil

15. Water transducer
16. Pneumatically controlled shut-off valve
17. Regulating valve
18. Solenoid valve block, water
19. Separator
20. Pressure transmitter, water
21. Drain valve

### Technical data

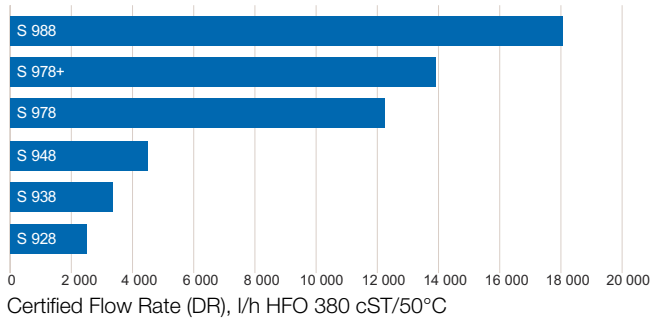

### Technical data

Main supply voltage	3-phase, 220 V up to 690 V
Control voltage	1-phase, 100/110/115/230 V
Frequency	50 or 60 Hz
Control air	Min 5 bar, max 8 bar
Operating water pressure	Min 2 bar, max 8 bar

### Dimensional drawing

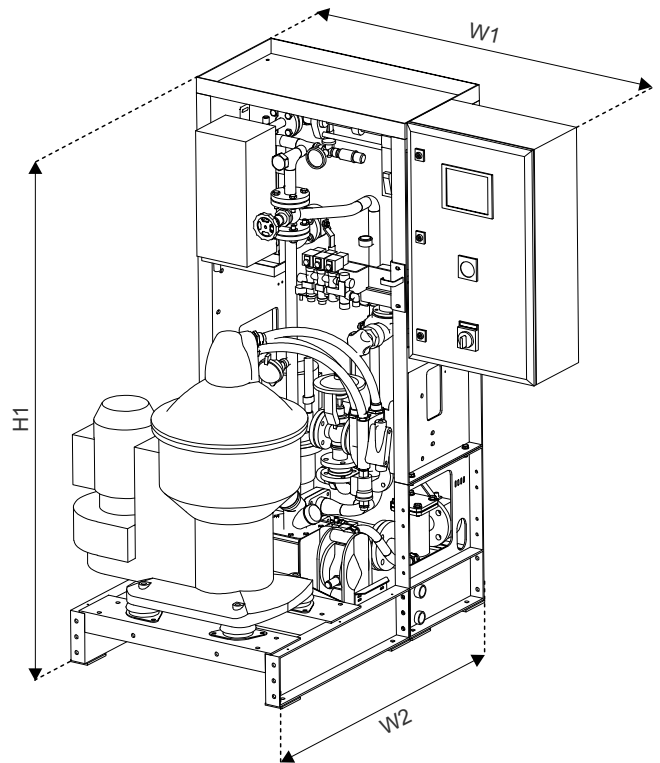

### Flex module with CBM heater

Type	Size (H1 x W1 x W2)	DN	Net weight (kg) <sup>1</sup>
S 928	1650 x 1200 x 1100	25	825
S 938	1650 x 1300 x 1220	25	830
S 948	1650 x 1300 x 1220	25	1010
S 978, S 978+	1900 x 1700 x 1650	40/50	2100
S 988	1900 x 1700 x 1650	40/50	2690

<sup>1</sup> Including ALP feed pump, CBM heater and SRK

This document and its contents are subject to copyrights and other intellectual property rights owned by Alfa Laval AB (publ) or any of its affiliates (jointly "Alfa Laval"). No part of this document may be copied, re-produced or transmitted in any form or by any means, or for any purpose, without Alfa Laval's prior express written permission. Information and services provided in this document are made as a benefit and service to the user, and no representations or warranties are made about the accuracy or suitability of this information and these services for any purpose. All rights are reserved.

### How to contact Alfa Laval

Up-to-date Alfa Laval contact details for all countries are always available on our website at [www.alfalaval.com](http://www.alfalaval.com)