



Alfa Laval MMB 304/305 Module

A robust and reliable separation system for mineral oil applications

Introduction

In marine and diesel industry, customers struggle with low-quality fuels that have high content in particles and water. Operating on such fuels reduces the efficiency and the lifetime of the engine while increases the risk of repair costs.

The MMB 304/305 Module is a complete separation solution from Alfa Laval that improves the reliability of the oil system and protects the main engine from serious wear and damages.

Application

- Distillate oil
- Marine diesel oil
- Lubricating oil

Benefits

- Easy to install and start up
- Easy to operate and maintain
- High separation efficiency
- Robust and reliable design

Design

The module consists of the separator, the frame, the pump, the inlet block, the outlet block, the flexible hose kit, the control cabinet and the emergency stop box.

The MMB 304/305 separators belong to Alfa Laval's family of solid bowl separators and consist of a solids-retaining bowl which can operate both as a purifier and a clarifier.

The pump block consists of a positive displacement pump with constant flow and an electric motor.

The inlet block is mounted on the pump and it is delivered with a ball valve, a strainer to protect the system from large particles, a non-return valve and a pressure gauge.

The outlet block is positioned in the oil outlet of the separator and consists of a non-return valve, a pressure switch, a pressure gauge and a regulating valve to control the backpressure of the system. The pressure switch triggers an alarm if the water seal is lost during operation.

Both the inlet and the outlet block are connected to the separator through flexible hoses which are included in the flexible hose kit.



All functions and alarms are being handled from the control cabinet which has been designed for simplicity and ease of use.

An emergency stop box is included to shut down the system in case of danger.

In addition to the standard configuration the following equipment can be selected as options.

A heater block, consisting of a CBM heat exchanger, a three-way and two temperature switches to ensure the right separation temperature during operation.

A drip tray installed in the bottom of the frame to collect any leakage media that may occur.

A collecting tank installed after the sludge outlet of the separator with an integrated level switch. The level switch will trigger an alarm if overflow occurs during operation.

A flow regulation kit with a regulation valve which is installed in the inlet block of the module.

Scope of supply

- MMB 304/305 separator
- Frame
- Pump
- Inlet block
- Outlet block
- Flexible hose kit
- Control cabinet
- Emergency stop box
- Manuals

Options

- Heater block
- Drip tray
- Collecting tank
- Flow regulating kit
- Set of tools
- Service kits

Working principle

The oil is being transferred directly from the pump to the separator. If it is required to warm up the oil, a heater and a three-way valve are installed between the pump and the separator. The three-way valve runs the oil on recirculation between the sump and the heater until the correct separation temperature is reached.

The separator starts up. When the separator reaches full speed, water is added to establish the appropriate water seal (applicable only for purifier setup). Subsequently, the pump starts up and oil is fed to the separator.

The separation process takes place within the bowl. Due to the centrifugal forces, oil, water and particles are being separated based on their specific gravity. The heavy phases, water and particles, are moving to the periphery of the bowl while the light phase, oil, is moving towards the center of the bowl.

Water is being drained automatically to the collecting tank. The separated particles need to be cleaned periodically by

hand. The clean oil is being pumped by a paring disc out of the separator and from there to the daily service fuel tank or the lube oil sump.

To secure the optimum operation of the separator a pressure switch, a level switch and two temperature switches are installed in the system. All the sensors are connected to the pump which will stop automatically if there is an alarm. In that case, the crew is informed by the alarm lamp on the control cabinet.

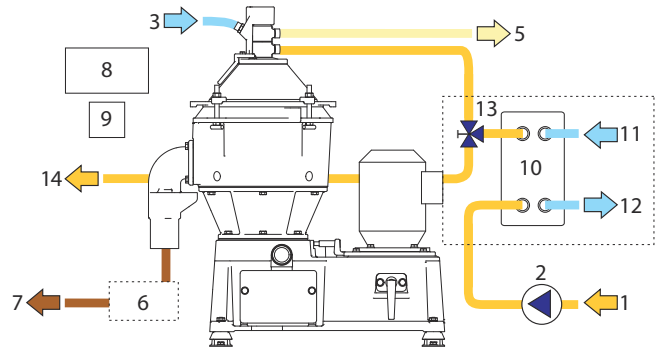

General flow chart of a separator system. The detail may differ slightly between different systems.

1. Feed inlet
2. Pump
3. Water for water seal (only for purifier)
4. Separator
5. Clean oil outlet
6. Collecting tank (optional)
7. Drain
8. Control cabinet
9. Emergency stop box
10. Heater (optional)
11. Heating media inlet (for module incl. heater)
12. Heating media outlet (for module incl. heater)
13. Three way valve (for module incl. heater)
14. Oil heat up recirculation (for module incl. heater)

Technical data

Performance data

Module	MMB 304	MMB 305
Feed capacities:		
- Gas oil (1,5 – 6 cSt/40°C)	Max. 2500 l/h (42 US gpm)	Max. 4700 l/h (78,3 US gpm)
- Marine diesel oil (13 cSt/40°C)	Max. 2100 l/h (35 US gpm)	Max. 3900 l/h (65 US gpm)
- Lube oil (Trunk/95°C)	Max. 700 l/h (11,6 US gpm)	Max. 1300 l/h (65 US gpm)
Separator motor power consumption	2,2 kW (0,9 HP)	3 kW (4,1 HP)
Pump motor power consumption	0,37 - 4 kW	
Feed temperature	Max. 100°C	
Bowl speed	9510 rpm	
Voltage	220 V, 230 V, 380 V, 400 V, 415 V, 440 V, 460 V, 480 V, 690 V	
Frequency	50 - 60 Hz	

Connections

Feed inlet	G 3/4 inch
Clean oil outlet	G 3/4 inch
Sealing water inlet	G 1/2 inch
Drain	Ø 76 mm
Heat media inlet	G 3/4 inch
Heat media outlet	G 3/4 inch

Material data

Separator frame	Cast iron
Separator bowl	Stainless steel, Brass
Module frame	Cast iron
Gaskets and O-rings	Nitrile rubber

Weights (approximate)

Module	MMB 304	MMB 305
Bowl weight	27 kg (59 lbs)	32 kg (70 lbs)
Separator weight without motor	147 kg (324 lbs)	179 kg (394 lbs)
Module weight (net/gross)	290 kg (639 lbs)	325 kg (716 lbs)
Module weight (net/gross) with heater	315 kg (694 lbs)	350 kg (771 lbs)
Volume	1,2 m ³	1,2 m ³

Dimensional drawing

Standard module

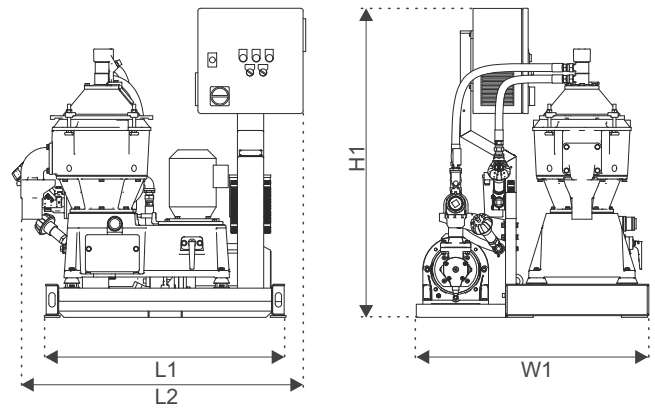

Module with CBM heater

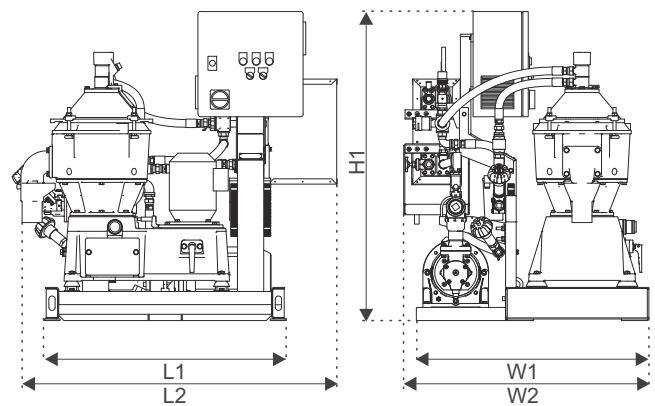

Dimensions

L1	920 mm (3 ft 1/4 inch)
L2	1070 mm (3 ft 6 1/8 inch)
L3	1197 mm (3 ft 11 1/8 inch)
W1	886 mm (2 ft 10 7/8 inch)
W2	934 mm (3 ft 3/4 inch)
H1	1176 mm (3 ft 10 5/16 inch)

This document and its contents are subject to copyrights and other intellectual property rights owned by Alfa Laval Corporate AB. No part of this document may be copied, re-produced or transmitted in any form or by any means, or for any purpose, without Alfa Laval Corporate AB's prior express written permission. Information and services provided in this document are made as a benefit and service to the user, and no representations or warranties are made about the accuracy or suitability of this information and these services for any purpose. All rights are reserved.

200000917-1-EN-GB

© Alfa Laval Corporate AB

How to contact Alfa Laval

Up-to-date Alfa Laval contact details for all countries are always available on our website at www.alfalaval.com