



# Alfa Laval HBPX 11000

## Disc stack separator system for protein applications

### Introduction

For more than 100 years, Alfa Laval has been supplying separators for various industries. Today, Alfa Laval has the most complete and diverse offering of separators – each fully optimized for its specific duty and supplied with all auxiliary systems and key components.

The use of disc stack separators in the production of animal fats and protein from fish and meat goes back to the 1920s. The applications range from rendering of edible animal fat and fish oil to technical fat and blood separation.

The Alfa Laval HBPX range is used to separate animal whole blood into two fractions; red cells haemoglobin and plasma, with the target to recover blood plasma in the best possible quality at maximized yield.

### Application

The HBPX 11000 is a high-performance separator, equipped with an optional control system, specifically designed and optimized to separate animal whole blood into two fractions.

Typical separation applications are the following:

- Fish and seafood processing
- Meat and poultry processing
- Pet food processing

### Benefits

- Easy to operate
- Easy to maintain
- Robust and reliable design
- Wear resistant
- Real time adjustment vs changing flow conditions
- Gentle treatment of the product

### Design

HBPX 11000 separation system consist of a separator which can be equipped with process liquid unit as well as Electrical & control system unit, either in form of a skid or a module.

The separator consists of a frame that contains a horizontal drive shaft, worm gear lubricating oil bath, and a hollow vertical bowl spindle. The bowl is fixed on top of the spindle, inside the space formed by the upper part of the frame, the solids collecting cover, and the frame hood. The hood carries the liquid discharge connections.



All metallic parts in connection with the process liquid are made of stainless steel.

The bowl is of the solids-ejecting disc type with an automatic hydraulic operating system for discharge.

The electric motor is for variable frequency drive.

The system (optional) is modularized and it can be configured from a selection of basic and other optional standardized units and control functions. The control system includes a PLC and a user-friendly HMI to monitor and control the separation process parameters. The system can be configured for remote operation.

### Scope of supply

The standard HBPX 11000 separation system includes the following main components:

- Disc stack centrifuge
- Cyclone
- OWMC (Operating Water Module Compact)
- Foundation plate
- Set of tools
- Commissioning spares

## Options

- Module/Skid & control system
  - The disc stack centrifuge can be fully equipped with custom-made standard Pprocess liquid unit as well as eElectrical & control system unit upon customer's request.
- Service
  - Commissioning
  - Operators training (basic and advanced level)
  - Basic service agreement
  - Performance agreement

## Working principle

The feed enters the rotating bowl from the bottom via the hollow drive spindle and accelerated in a distributor before entering the disc stack. Separation takes place between the discs as a result of the centrifugal force that causes the solids to move towards the periphery.

The clarified light liquid phase moves towards the centre of the bowl and leave the separator by being pumped out by an impeller. The clarified heavy liquid phase moves towards the periphery and leave via the top disc and is pumped out by an impeller.

The solids collected in the periphery of the bowl are discharged intermittently through the discharge ports and decelerate in the sludge cyclone.

A hydraulic system below the separation space in the bowl is used to control the movement of the sliding bowl bottom part that opens and closes the discharge ports.

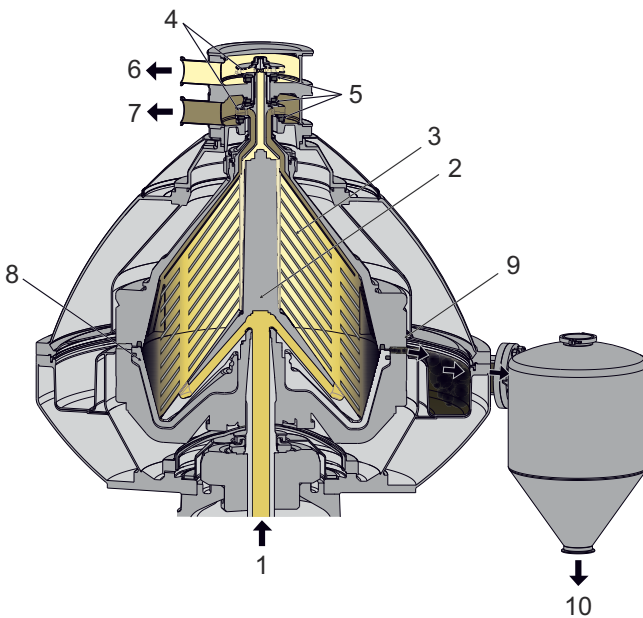

1. Inlet
2. Distributor
3. Disc stack
4. Impeller
5. Hermetic seal
6. Light liquid phase outlet
7. Heavy liquid phase outlet
8. Sliding bowl bottom
9. Solids discharge ports
10. Solids outlet from cyclone

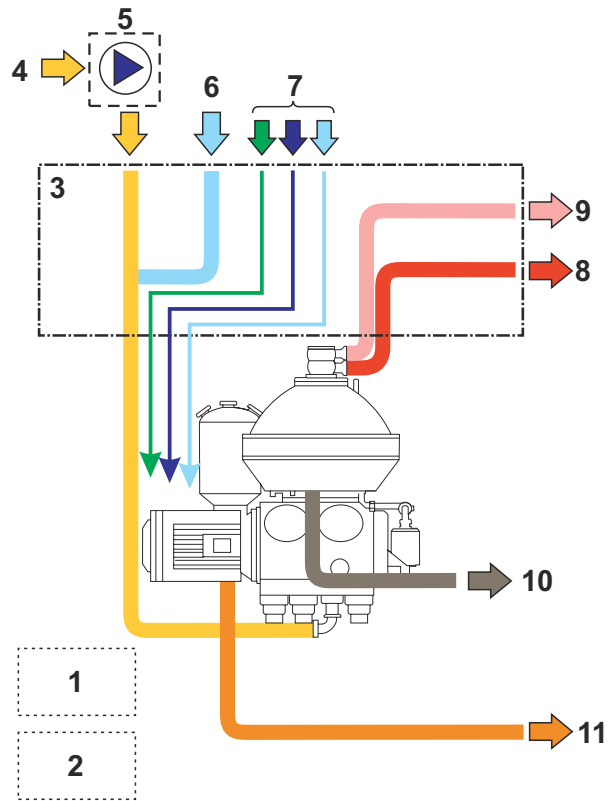

Typical flow chart of a separator system. The details may differ based on the actual order.

1. Control cabinet (optional)
2. Motor starter cabinet and VFD (optional)
3. Process & service liquid unit (optional)
4. Product inlet
5. Feed pump (optional)
6. Standby/Safety water
7. Utilities
8. Heavy phase outlet
9. Light phase outlet
10. Separator drain
11. Discharged solids outlet

## Technical data

### Performance data<sup>1</sup>

Maximum capacity	DN50:	20 000 litre/h
	DN65:	35 000 litre/h
	DN80:	55 000 litre/h
Maximum discharge capacity		35 litre
Maximum motor power		55 kW
Sound pressure level		78 dB

<sup>1</sup> Actual capacity and power consumption depend on operating conditions

### Connections

Feed inlet	DIN 63.5, ISO 2852 Clamp coupling
Heavy phase (blood corpuscles) outlet	DIN 63.5, ISO 2852 Clamp coupling
Light phase (plasma) outlet	DIN 63.5, ISO 2852 Clamp coupling
Solids outlet	DIN 200

### Material data

Bowl body & lock ring	Stainless steel, EN 1.4501, UNS 32762
Frame top part	Austenitic Stainless steel, EN 1.4401, ASTM S31600
Frame bottom part	Cast iron, clad with stainless steel, EN 1.4301, UNS 30400
Inlet and outlet parts	Austenitic Stainless steel, EN 1.4401, STM S31600
Gaskets (product wetted)	Nitrile FDA

### Weights

Separator, bowl and motor	2440–2516 kg (5.379–5.547 lbs)
Bowl	1150 kg (2.535 lbs)

### Dimensional drawing

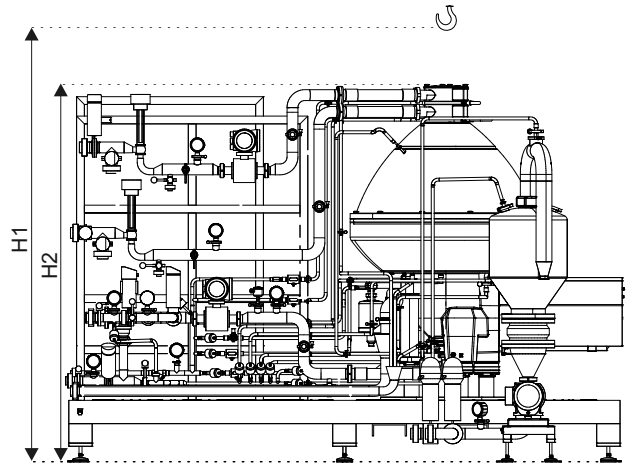
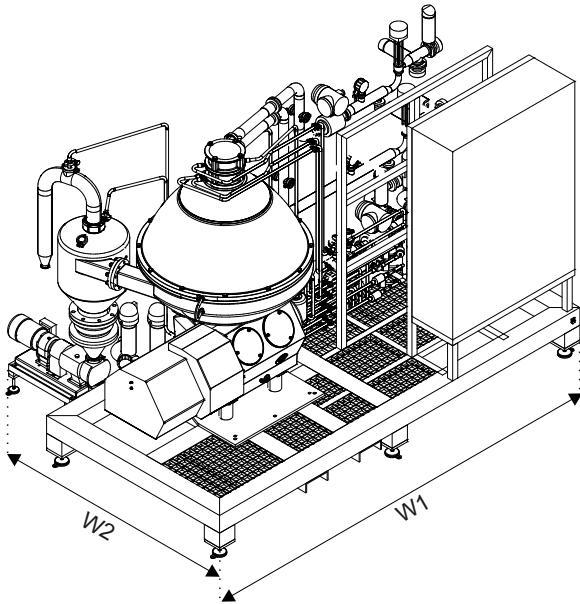

H1	Minimum 3350 mm (10 ft 11 57/64 inches)
H2	2415 mm (7 ft 11 5/64 inches)
W1	3540 mm (11 ft 7 3/8 inches)
W2	2615 mm (8 ft 6 61/64 inches)

This document and its contents are subject to copyrights and other intellectual property rights owned by Alfa Laval Corporate AB. No part of this document may be copied, re-produced or transmitted in any form or by any means, or for any purpose, without Alfa Laval Corporate AB's prior express written permission. Information and services provided in this document are made as a benefit and service to the user, and no representations or warranties are made about the accuracy or suitability of this information and these services for any purpose. All rights are reserved.

200001760-1-EN-GB

© Alfa Laval Corporate AB

### How to contact Alfa Laval

Up-to-date Alfa Laval contact details for all countries are always available on our website at [www.alfalaval.com](http://www.alfalaval.com)