

Alfa Laval Clara 600D

Disc stack separation system for food and beverage applications

Introduction

For more than 100 years, Alfa Laval has been supplying separators for various industries. Today, Alfa Laval has the most complete and diverse offering of separators – each fully optimized for its specific duty and supplied with all auxiliary systems and key components.

The use of disc stack separators in different food and beverage applications goes back several decades. Based on the long-term cooperation with the food and beverage industry, Alfa Laval separators are specifically designed for the requirements and demands of this industry.

The Clara range of high-speed separators is specially developed for food, beverage and industrial fermentation applications. The Clara range offers gentle product treatment, high separation efficiency and low power consumption.

Application

Self-cleaning disc stack separation systems in the Clara series are optimally designed to ensure high performance and maximized yield for clarification duties in the food and beverage industries and for other hygienic applications.

Typical separation applications are clarification of the following products:

- Wine
- Fruit juices
- Vegetable juices
- Coffee and tea
- Egg white

Benefits

- High separation efficiency
- Gentle treatment of the product
- Low power consumption
- Minimal product loss
- Robust and reliable design

Design

The Clara 600D separation system consists of a separator, a process & service liquid unit, and an electrical & control system.

The unique hermetic bottom fed design ensures superior separation performance and offers the lowest power



consumption in the market. The liquid outlet is sealed by the Oxystop hydro-hermetic seal that prevents oxidation of the clarified product. Adjustable discharge volume function ensures discharge of solids with high dry matter content, thus minimizing product losses.

The system is modularized and it can be configured from a selection of basic and optional features and control functions. The control system includes a PLC and a user-friendly HMI to monitor and control the separation process parameters. The system can be configured for remote operation.

All metallic parts in contact with the process liquid are made of stainless steel. Gaskets and seals in contact with the product are made of FDA approved material and are approved according to food regulations (EC-1935/2004).

The separation system is designed for automated Cleaning in Place (CIP).

Scope of supply

The standard Clara 600D modularized system includes the following main components:

- Disc stack separator
- Process & service liquid unit:
 - Valves, instruments and other components
 - Flow and back pressure regulation valves
 - Flow meter
 - Sight glasses
 - Sample valves
 - Timer triggered solids discharge function
- Electrical & control system:
 - Control cabinet with PLC and touchscreen HMI
 - Motor starter cabinet with VFD
- Commissioning spares
- Set of special tools
- Documentation
- The system is available in two pipe size configurations:
 - DN50, DN65 and DN80

Options

- Feed pump
- Solids receiving unit (a collection device and a transfer pump for the discharged solids)
- Turbidity triggered solids discharge function
- Capacity control by inlet turbidity
- Service options:
 - ConditionAlert (TM) — connectivity based subscription
 - Commissioning
 - Operators training (basic and advanced level)
 - Basic service agreement
 - Performance agreement

Working principle

The process & service liquid unit monitors and regulates the flow and pressure of the feed and utility liquids in and out of the separator.

The process liquid is continuously fed from the bottom into the rotating separator bowl through the hollow drive spindle. Separation takes place between the bowl discs due to the centrifugal force. The solids settle towards the periphery of the bowl. The clarified/separated liquid is continuously pumped out of the hydro-hermetically sealed outlet by a paring disc at the top of the separator.

The solids collected in the periphery of the bowl are discharged intermittently through the discharge ports. The discharge is triggered by a timer or by a turbidity meter, placed in the outlet of the system.

Water is used to control the movement of the sliding bowl bottom part that opens and closes the discharge ports. The discharged solids decelerate in the sludge cyclone and can be pumped out of the system by the optional solids receiving unit.

The process & service liquid unit also controls the separator's discharge system, flushing, and CIP.

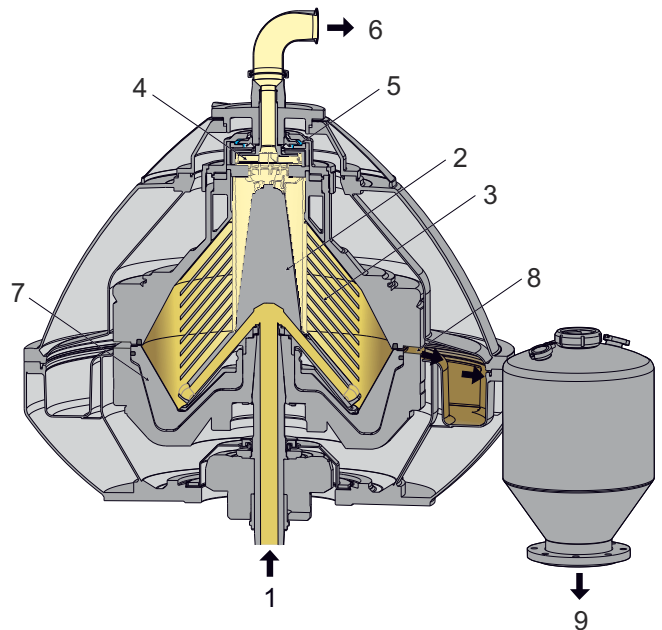

Typical bowl drawing for a solids-ejecting separator. The details illustrated do not necessarily correspond to the separator described

1. Inlet
2. Distributor
3. Disc stack
4. Paring disc
5. Hydro hermetic seal
6. Liquid phase outlet
7. Sliding bowl bottom
8. Solids discharge ports
9. Solids outlet from cyclone

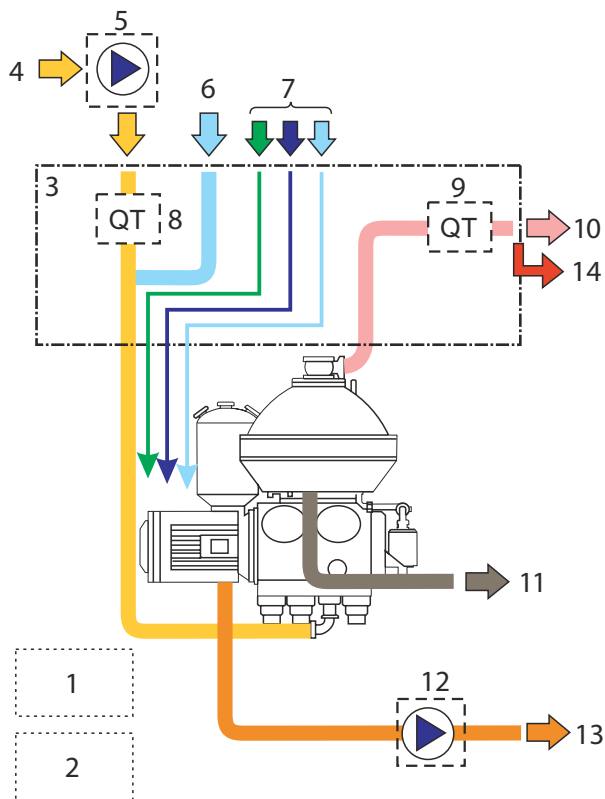

Typical flow chart of a separator system. The details may differ slightly between different systems.

1. Control cabinet
2. Motor starter cabinet and VFD
3. Process & service liquid unit
4. Product inlet
5. Feed pump (optional)
6. Standby/Safety water
7. Utilities
8. Turbidity meter for capacity control (optional)
9. Turbidity meter for discharge triggering (optional)
10. Outlet for clarified product
11. Separator drain
12. Solids receiving unit (optional)
13. Discharged solids outlet
14. Process and service liquid unit drain

Technical data

Performance data

Max capacity ¹	DN50: 20 000 l/h (88 US gpm)
	DN65: 35 000 l/h (154 US gpm)
	DN80: 50 000 l/h (220 US gpm)
Max. motor power	45 kW (60.3 HP)

¹ Actual capacity and power consumption depend on application, solids content and operating conditions

Connections

Feed inlet	DIN 11851 Union DN50 / 65 / 80
Product outlet	DIN 11851 Union DN50 / 65 / 80
Solids outlet	DIN Flange DN80

Material data

Bowl body	Stainless Steel, EN 1.4418
Gaskets (product wetted)	NBR and EPDM, FDA approved
Piping	Stainless steel, AISI 316L
Frame and cabinet	Stainless steel, AISI 304

Weights

System incl, separator, bowl and motor	3225 kg (7110 lbs)
Bowl	1150 kg (2535 lb)

Dimensional data

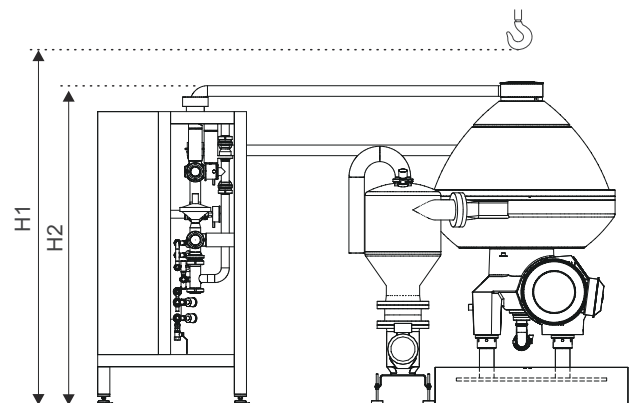
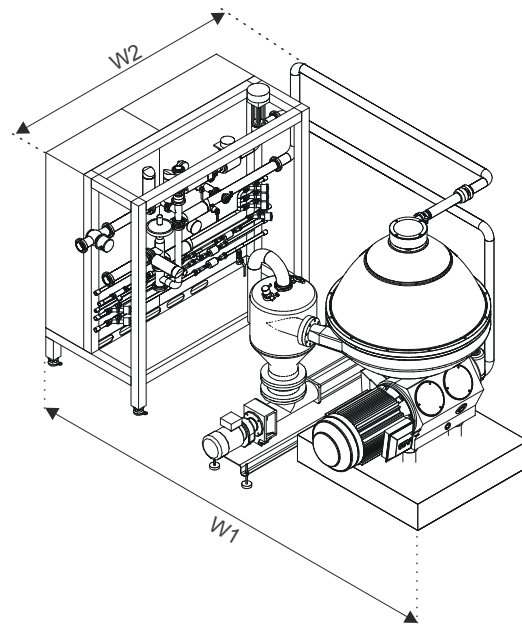

Dimensions

H1	3030 mm (9 ft 11 5/16 inches)
H2	2200 mm (7 ft 2 5/8 inches)
W1	3600 mm (11 ft 9 3/4 inches)
W2	2400 mm (7 ft 10 1/2 inches)

This document and its contents are subject to copyrights and other intellectual property rights owned by Alfa Laval Corporate AB. No part of this document may be copied, re-produced or transmitted in any form or by any means, or for any purpose, without Alfa Laval Corporate AB's prior express written permission. Information and services provided in this document are made as a benefit and service to the user, and no representations or warranties are made about the accuracy or suitability of this information and these services for any purpose. All rights are reserved.

200005514-1-EN-GB

© Alfa Laval Corporate AB

How to contact Alfa Laval

Up-to-date Alfa Laval contact details for all countries are always available on our website at www.alfalaval.com