



MBPX 810H

Medium-sized solids-ejecting centrifuge for the fermentation & biotech industries



MBPX 810H complete with motor

The MBPX 810H is a medium capacity fully hermetic unit in the range of centrifuges specially built for microbiological applications. The separation duties met with often require very high bowl speeds for an optimal performance in separation of solid particles with very small diameters. The unique hermetic design with bottom feed gives not only a gentle acceleration of shear-sensitive particles, such as protein precipitates; it also prevents air entrainment that can cause problems in the downstream filtration process. The hermetic inlet leads to maximum separation efficiency by minimizing cell lysis. This also prevents release of unwanted intracellular proteins. The separation efficiency is further enhanced by a bowl geometry that uses the pseudo-plastic nature of the solids phase. Flow control devices can be located downstream thus enabling implementation of an obstruction-free, full-bore feed arrange-

ment. Special attention has been paid to a hygienic, CIP-able design.

Applications

The MBPX 810H is used for removing suspended solids with particle sizes of approx 0,5 to 500 μm from a liquid having lower density than the solids. The solids content is usually in the range of 0,1 to 20% by volume. The main applications are bacteria separations, rDNA products, enzymes, cell cultures and vaccines. It is also suitable for industrial fermentation processes where microbial cells are used for production of acids, chemicals, fuels, etc. Applications that require low oxygen pick-up can also take advantage of the hermetic features offered by this machine. The maximum process capacity is 15 m³/h.

Standard design

The machine consists of a frame that has a horizontal drive shaft, worm gear, lubricating oil bath and a hollow vertical bowl spindle in the lower part.

The bowl is mounted on top of the spindle, inside the space (bowl casing) formed by the upper part of the frame, the solids collecting cover and the frame hood. The bowl casing is double-walled for cooling and noise reduction. All metal parts in contact with the process liquid are made of stainless steel. The bowl shell is made from the corrosion resistant stainless steel EN 1.4462 (UNS S31803). The bowl is of the solids-ejecting disc type with an automated hydraulic operating system for discharging. It is a so-called timer triggered discharge system, meaning that the bowl content is emptied at pre-set discharge intervals. In production normally only part of the bowl content is emptied, whereas during CIP total discharges are possible. The variable partial discharge takes place at full speed without any interruption of the feed. The discharged solids enter a cyclone connected to a tank or a pump. The hydraulic/pneumatic system for the discharge is mounted on the lower part of the frame.

The centrifuge is available with main connections as sanitary clamps and all other utility connections of clamp type.

The electric motor is suitable for variable frequency drive.

The drive system is splash-lubricated without any need for an external lubrication circuit. The design conforms to a number of EC directives, and the machine is made in accordance with the general directives for machinery. The machine is equipped with nozzles for flushing of the bowl top, the bowl bottom and the solids collecting chute. The tools for assembly and disassembly of the bowl are made of stainless steel.

Operating principles

The feed is introduced into the rotating centrifuge bowl via a hollow bowl spindle (1) and is accelerated in the distributor (2) before entering the disc stack (3). It is between the discs that the separation takes place.

The liquid phase moves towards the center of the bowl, from where it is pumped out under pressure by means of a built-in pump (4). The heavier solids phase is collected in the periphery of the bowl and are discharged at preset intervals through a cyclone.

The solids discharge is achieved by a hydraulic system below the separation space in the bowl. When at pre-set intervals, the sliding bowl bottom (5) is forced to drop down, solids ports (6) are opened for the solids to be discharged.

Design features

- Fully hermetic design for minimal shear stress, absence of oxygen, low power consumption and low noise level.
- Adjustable discharge volume ensuring discharge of solids with high dry matter content, thus minimising product losses or down-stream processing costs.
- High separation capacity due to the bowl geometry.
- Designed for easy cleaning-in-place (CIP).
- All product wetted polymers and seal rings compliant with FDA regulations or USP Class IV regulations.
- FDA compliant materials in the mechanical seals.

Options

Two different disc stacks for different solids space volumes are available.

The centrifuge can be supplied as a complete system with the centrifuge mounted on a fixed base frame. On this frame is included process piping for liquids entering and leaving the centrifuge and for service media. Typically an optional pump removes the solids phase.

The built-in electrical system includes starter for variable frequency drive, a PLC unit and a pneumatic unit.

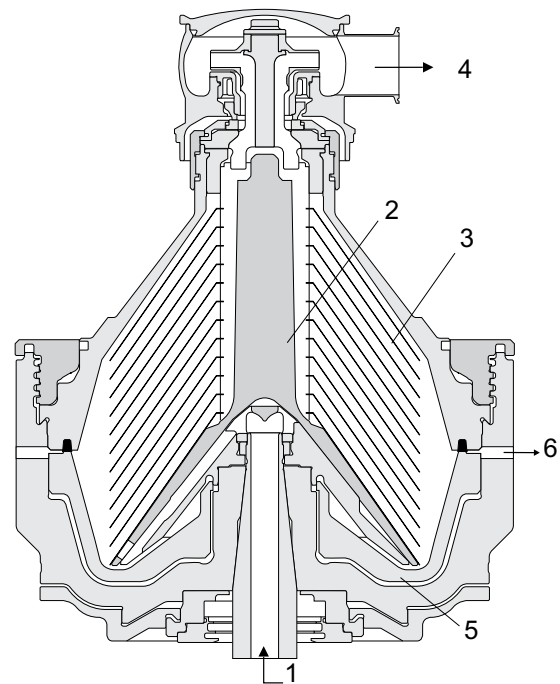

Typical bowl drawing for a fully hermetic solids ejecting centrifuge. Drawing details do not necessarily correspond to the centrifuge described.

Utilities consumption

Power consumption	12.5 kW @ 15 m ³ /h (17 HP @ 66 US gpm)
Water consumption per discharge	1 l (0.26 US gal)
Required discharge water pressure	max. 50 kPa (7 psi)
Seal cooling water	120–160 l/h
Jacket cooling water consumption	150 l/h

Material data

Bowl body, hood and lock ring	EN 1.4462 UNS S31803
Distributor	EN 1.4401 UNS 31600
Solids cover and frame hood	EN 1.4401 UNS 31600
Inlet and outlet parts	EN 1.4401 UNS 31600
Frame bottom part	Cast iron
Gaskets and O-rings	EPDM rubber ¹⁾
Bowl tools	EN 1.4401 UNS 31600

¹⁾ In accordance with FDA 21 CFR or USP Class IV.

Connections

Product inlet, outlet Clamp	NW 63.5 acc. to ISO 2037
Solids cyclone pipe Clamp	NW 63.5 acc. to ISO 2037

Technical specifications

Throughput capacity	max. 15 m ³ /h (66 US gpm)
Solids handling capacity	max. 600 l/h
Feed temperature range	0–100 °C
Bowl volume	15 liters
Bowl speed	6,250 rpm
Solid space volume	5.0/9.8 liters
G-force	8,624
Motor power installed	15/18.5 kW (20/25 HP)
Motor speed synchronous 50 Hz	1,500 rpm
Inlet pressure at 15 m ³ /h at centrifuge inlet flange	200 kPa ¹⁾
Starting time	5 mins
Stopping time without brake (average)	16 mins
Sound pressure	76 dB(A) ²⁾
Overhead hoist lifting capacity	min. 900 kg

¹⁾ At 15 m³/h with outlet pressure 260 kPa.

²⁾ According to EN ISO 4871.

Shipping data (approximate)

Centrifuge incl. bowl and motor	1,370 kg (3,020 lbs)
Bowl	310 kg (685 lbs)
Gross weight	2,000 kg (4,410 lbs)
Volume	4–5 m ³

Dimensions

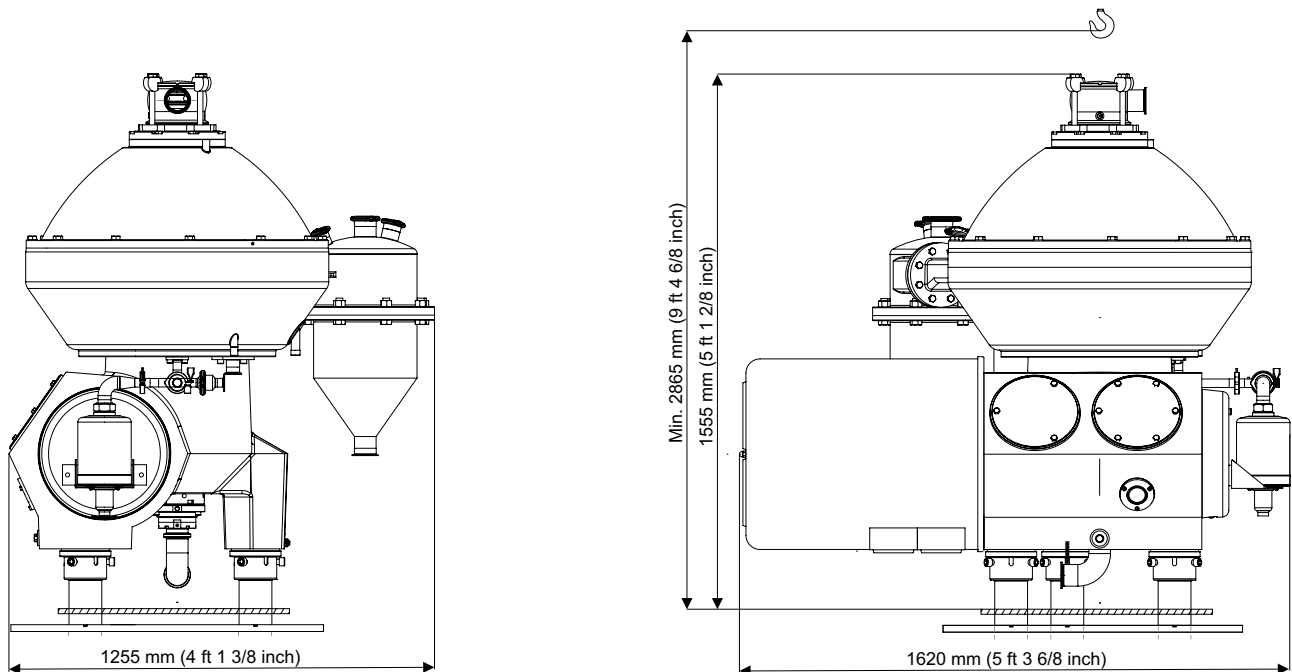

How to contact Alfa Laval

Up-to-date Alfa Laval contact details for all countries are always available on our website at www.alfalaval.com.