

# Alfa Laval AlfaFlash ZLD MVR systems

Recover water for reuse and reduce disposal costs



## Introduction

Alfa Laval AlfaFlash ZLD (Zero Liquid Discharge) systems eliminate wastewater, recover water for reuse and separate solids for recycling or to dispose off economically.

Alfa Laval is a leader in both evaporation and centrifugal separation technologies. The combination of these two provides distinct advantages to many companies across a broad range of industries.

AlfaFlash ZLD MVR removes water using the efficient Mechanical Vapour Recompression evaporation technology and separates the solids using centrifugal separation.

With AlfaFlash ZLD, companies can be more efficient in both treating their wastewater as well as recovering and recycling key resources such as water, salts, metals, and other chemicals. Resources which otherwise may have gone to waste.

## Applications

AlfaFlash ZLD can be used for the following applications:

- RO reject
- Waste water from (bio-) chemical processes
- Wash water from metal manufacturing processes
- Chemical recycling by crystallization
- Leaching
- Cooling tower blow-down

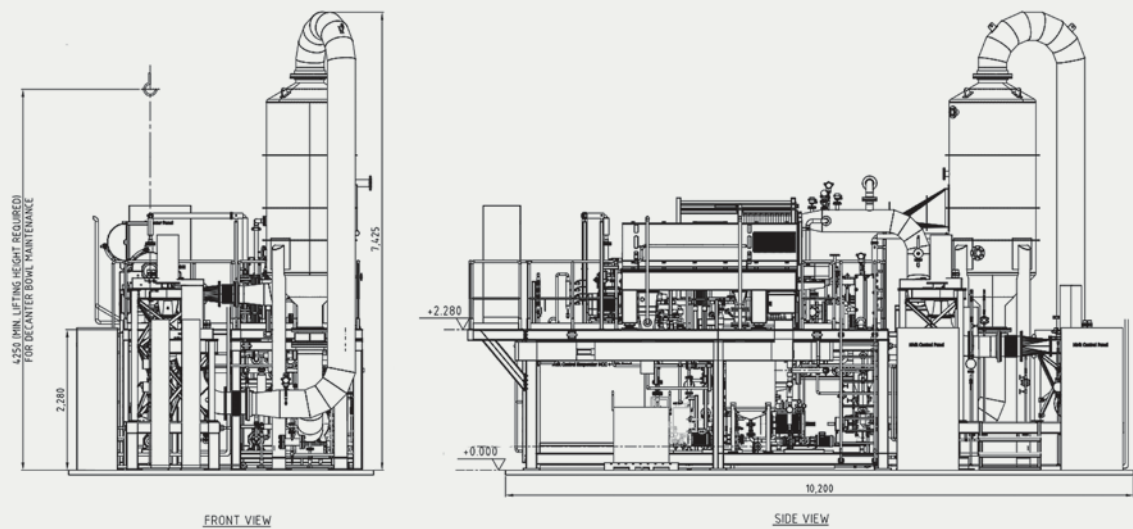

AlfaFlash ZLD MVR-D 1E-2.5 main dimensions

## Benefits

There are many benefits, many of them shared across the entire range of applications where AlfaFlash ZLD is useful.

Here are some of them:

- Recover up to 99% water for reuse
- Separate solids with dryness up to 90%
- Using MVR, no steam and cooling water needed
- Corrosion resistant materials, such as titanium and super duplex
- Modular, pre-assembled system
- Robust and reliable handling of process variations
- World-wide service coverage

## Design

The design and operation of the pre-assembled, fully automatic AlfaFlash ZLD system takes into consideration the fact that many facilities do not have steam or cooling water available. AlfaFlash ZLD features the most resilient evaporator technology available on the market, building upon Alfa Laval's world-leading experience in heat exchanger technology. The system offers high thermal efficiency with very low electricity consumption per kg of treated water.

## Technical data

| Model                      | Water evaporation capacity (kg/h) | Consumed power (kW) | Total empty weight (kg) | Overall Footprint Dimensions L x W x H (mm) |
|----------------------------|-----------------------------------|---------------------|-------------------------|---|
| AlfaFlash ZLD MVR-D 1E-1.5 | 1500                              | 145                 | 19850                   | 8300 x 4500 x 7500                          |
| AlfaFlash ZLD MVR-D 1E-2.5 | 2500                              | 163                 | 20200                   | 10200 x 4950 x 7425                         |
| AlfaFlash ZLD MVR-D 1E-3.5 | 3500                              | 213                 | 22900                   | 11500 x 5150 x 7900                         |
| AlfaFlash ZLD MVR-D 1E-6   | 6000                              | 392                 | 41900                   | 16200 x 8300 x 9500                         |

All models in the list include the optional Alfa Laval decanter.

Smaller and larger capacities, as well as steam-driven systems, are available on request as customized solutions.

With the optional Alfa Laval decanter centrifuge, the solids can be removed with a high dryness, even with considerable fluctuation in the upstream process. Decanter centrate is returned to the evaporation system for further concentration into solids that can be removed.

## Options

Decanter centrifuge system for dryer solids separation.

## Working principle

The water to be treated is pre-heated and sent to an evaporator, where the water is boiled-off to leave behind a concentrated brine or slurry with crystals. This concentrate stream is then (optionally) fed to a decanter centrifuge, to obtain a high dryness of the solids. Solids can then be recycled or disposed of safely, such as by landfill or incineration.

The boiled-off water is condensed and returned to the process for reuse, so that no liquid waste is discharged into the environment. By using MVR technology, the heat of condensation is fully recovered.

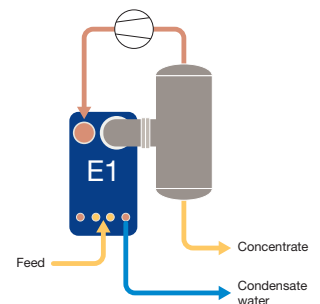

Working principle

This document and its contents are subject to copyrights and other intellectual property rights owned by Alfa Laval Corporate AB. No part of this document may be copied, re-produced or transmitted in any form or by any means, or for any purpose, without Alfa Laval Corporate AB's prior express written permission. Information and services provided in this document are made as a benefit and service to the user, and no representations or warranties are made about the accuracy or suitability of this information and these services for any purpose. All rights are reserved.

## How to contact Alfa Laval

Up-to-date Alfa Laval contact details for all countries are always available on our website at [www.alfalaval.com](http://www.alfalaval.com)