

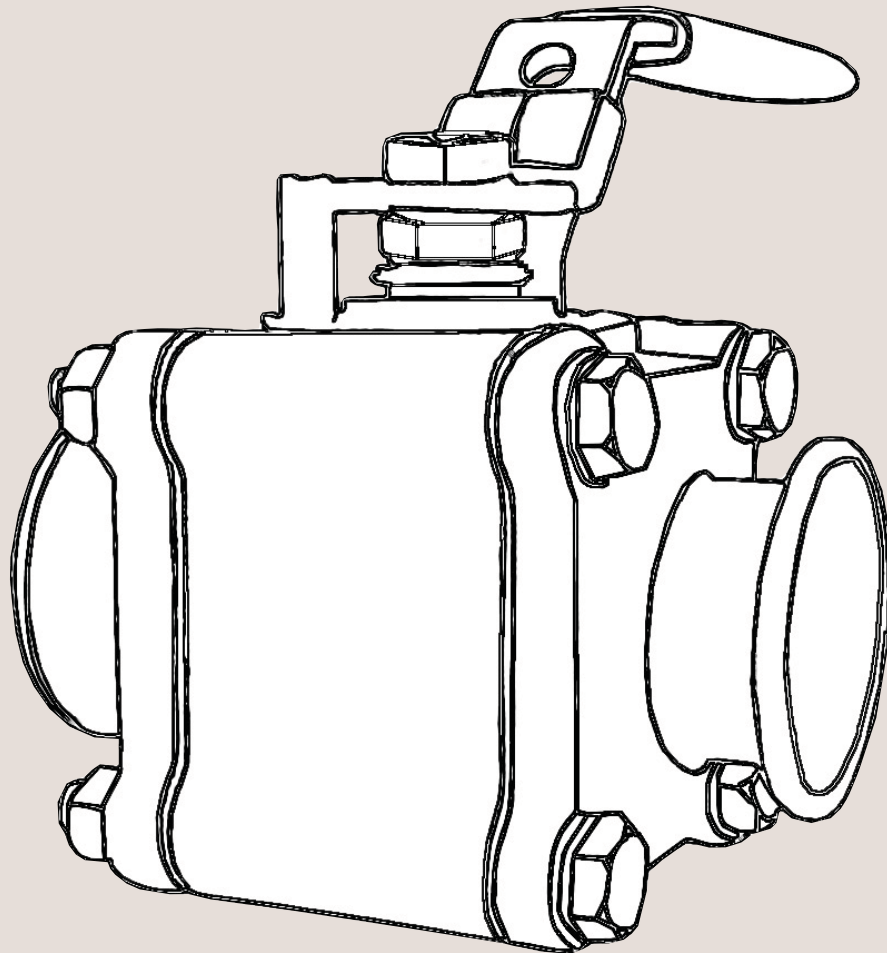

Instruction Manual

5308/5309 Ball Valve / Ball Valve UltraPure



ESE01663-EN3 2011-06

Original manual

The information herein is correct at the time of issue but may be subject to change without prior notice

1. Safety	4
1.1. Important information	4
1.2. Warning signs	4
1.3. Safety precautions	5
2. Maintenance	6
2.1. Valve Disassembly	6
2.2. Valve Inspection	6
2.3. Valve Assembly	7
2.4. Attaching the actuator and switch to the valve	9
3. Technical data	10
3.1. Torque vs Pressure Differential	10
4. Parts list and Service Kits	12
4.1. Ball Valves, UltraPure for 1/2" to 2"	12
4.2. Ball Valves, UltraPure for 2 1/2" to 4"	14
4.3. Ball Valve, 5308 Series for 1/2" to 2"	16
4.4. Ball Valve, 5308 Series for 3" to 4"	18

1 Safety

*Unsafe practices and other important information are emphasized in this manual.
Warnings are emphasized by means of special signs.*

1.1 Important information

Always read the manual before using the valve!

WARNING

Indicates that special procedures must be followed to avoid serious personal injury.

CAUTION

Indicates that special procedures must be followed to avoid damage to the valve.

NOTE

Indicates important information to simplify or clarify procedures.

1.2 Warning signs

General warning:



Caustic agents:



All warnings in the manual are summarized on this page.
Pay special attention to the instructions below so that severe personal injury and/or damage to the valve are avoided.

1.3 Safety precautions

Installation

Always read the technical data thoroughly.



Always release compressed air after use.



Operation

Always read the technical data thoroughly.



Never touch the valve or the pipelines when processing hot liquids or when sterilizing.



Always handle lye and acid with great care.



Maintenance

Always read the technical data thoroughly.



Always release compressed air after use.



Never service the valve when it is hot.



Never service the valve with valve and pipelines under pressure.



Never stick your fingers through the valve ports if the actuator is supplied with compressed air.



2 Maintenance

All warnings in the manual are summarized on this page.

Pay special attention to the instructions below so that severe personal injury and/or damage to the valve are avoided.

2.1 Valve Disassembly

To disassemble a ball valve:

1. For a manual valve, remove the top handle nut (20) from the stem (4)
2. Remove the handle (7). For actuated valves remove bracket mounting bolts and remove actuator/bracket and coupler

Note: If you are disassembling a 3 or 4 inch valve, you'll need to remove the actuator mounting bolts.

3. To remove the second stem nut you must first bend back the side tab of the stop washer (12). This can be done using a screw driver or punch. Once the stop washer side tab is flattened you can remove the stem nut (5)

Note: 3 and 4 inch valves will require a socket wrench to reach the nut recessed into the mounting bracket. 36 mm.

4. Remove bevel washers (6) and gland bushing (9)
 5. Remove four hex nuts (17) from one side of body bolts (14). For the 4 inch valve remove six hex nuts (17). Remove body bolts/studs to allow bodyends (2) to fall away
 6. Remove the front and rear ball seats (8)
 7. Turn the stem (4) clockwise until the ball (3) is in the closed position, allowing the ball to fall free from the valve
 8. Press downward on the stem (4) until it presses through the inside of the valve body (1), and remove the stem and bottom stem seal (11) and the stem packings (10)
 9. Remove the joint gasket (5) from valve body ends. (You will need to use a small instrument, such as a dental pick or small screw driver to pry the o-ring away from the body end. Be careful not to mar the body end in the process)
-

2.2 Valve Inspection

Seat(s)

1. Carefully examine the PTFE valve ball seats for cracking, checking or excessive wear. Leakage past the seat(s) may result from these types of irregularities.

Surface Finish

2. Inspect the bore of the ball and the valve stem in the valve upper body for signs of galling. Replace both if galling exists. Galling will continue to occur if only one part is replaced and the other is damaged. Inspect the inside surface of each body end for marring. Replace the end if damaged. Leakage may occur from this kind of damage

Gaskets/O-ring(s)

3. Inspect for cracks, cuts, abrasions, flat spots or other damage that would cause leakage or ineffective cleaning. Replace as necessary
-

All warnings in the manual are summarized on this page.

Pay special attention to the instructions below so that severe personal injury and/or damage to the valve are avoided.

2.3 Valve Assembly

To assemble a ball valve:

1. Place the lower packing ring (11) on the valve stem (4) and slide the stem into the stem hole in the upper body of the valve
2. Press the upper packing rings (10) onto the stem (4) until it is seated against the base of the body
3. Press the packing retainer (9) onto the stem (4) until it is seated against the upper packing ring (10)
4. Turn the stem (4) until the flat surfaces are parallel to the port centerline
5. Place a ball seat (8) inside one end of the valve body (1) so that the tapered side of the seat faces inward and the other side lies flush against the outer surface of the valve body
6. Seat the ball (3) inside the valve so that the stem base is seated inside the bore of the ball

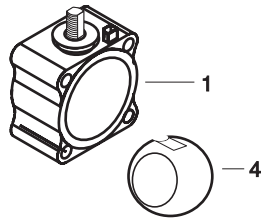
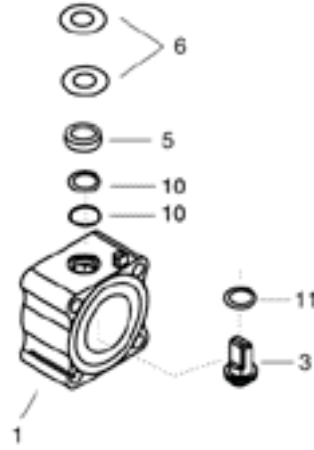

7. Turn the stem 90° so that the valve is in the open position. This keeps the ball from falling out of the valve
8. Place the other ball seat (8) inside the end of the valve body (1) so that the tapered side of the seat faces inward and the other side lies flush against the outer surface of the valve body

3" and 4"

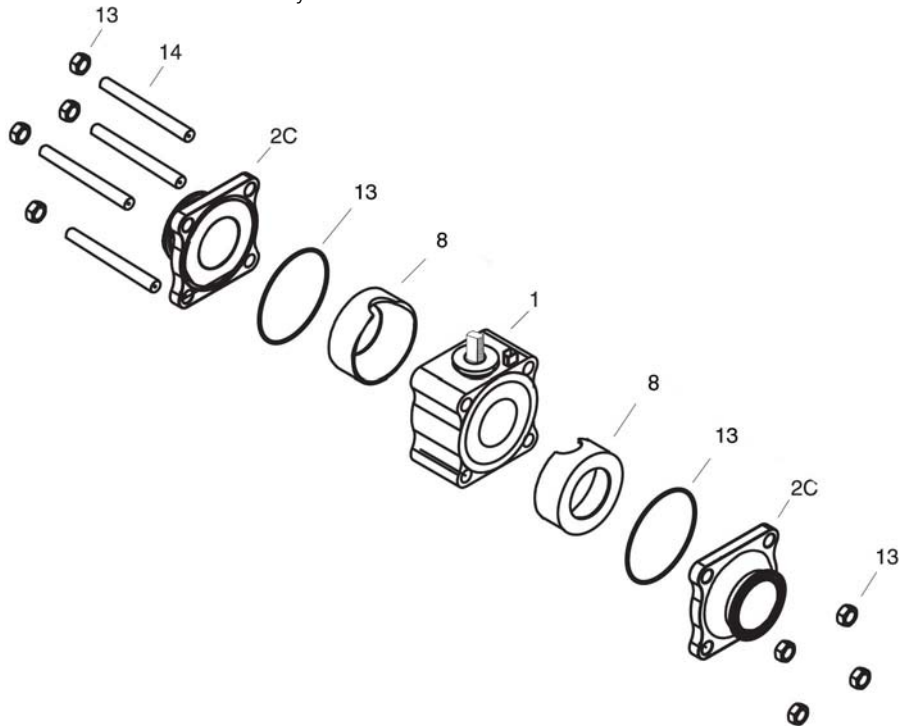

2 Maintenance

All warnings in the manual are summarized on this page.

Pay special attention to the instructions below so that severe personal injury and/or damage to the valve are avoided.

9. Assemble the valve body ends (2), with gaskets (13) in place, to each end of the valve body (1). ½" through 2" size use 4 bolts (14) and 4 bolt nuts (17). 3" and 4" size, use 4 studs (14) and 8 stud nuts (17). Refer to Table 1 for proper torques
10. Place spring washers (6) together so that their curved surfaces are facing outward, in opposite directions, and place them over the stem (4)
11. Place stop washer (12) onto stem (4). Making sure the stop washer lock tab is flat. Instal stem nut (5) onto valve stem (4). Refer to table 2 for stem nut tightening torque.
Once stem nut is properly tightened, bend tab of lock washer (12) up against the stem nut (5) using a screwdriver or punch. Instal handle (7) over valve stem (4) and secure with handle nut (20). Be sure the handle locking devise (18) will align with both locking notches in valve body (1).
If you are using an electric or pneumatic valve, place the actuator/bracket assembly on the upper body of the valve, and secure it to the valve with two mounting bracket screws.

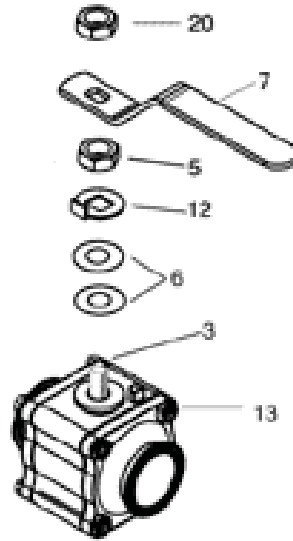

Bolting Torque Data for Sanitary Ball Valves

Table 1.

Valve Size	For Body Bolting		
	Size	in-lb	NM
½"	¼" - 20unc	80	9
¾"	¼" - 20unc	80	9
1"	5/16" - 18unc	110	12
1½"	3/8" - 16unc	170	19
2"	7/16" - 14unc	230	26
3"	5/8" - 11unc	570	64
4"	5/8" - 11unc	600	68

Table 2.

Valve Size	For Stem Unit		
	Size	in-lb	NM
½"	3/8" - 24unf	87	9.8
¾"	3/8" - 24unf	87	9.8
1"	3/8" - 24unf	87	9.8
1½"	7/16" - 20unf	122	13.7
2"	9/16" - 18unf	165	18.6
3"	M24	191	21.6
4"	M24	191	21.6

All warnings in the manual are summarized on this page.

Pay special attention to the instructions below so that severe personal injury and/or damage to the valve are avoided.

2.4 Attaching the actuator and switch to the valve

Attaching the Switch to the Actuator:

1. Remove the position indicator on the top of the actuator (1)
2. Attach the bracket (10) to the top of the actuator using four bolts (11)
3. Insert the switch stem through the center hole in the bracket (10) and align with the slot in the actuator shaft
4. Attach the top of the bracket (10) to the switch using four bolts (9)

Attaching the Actuator to the Valve:

These instructions describe how to attach an assembled actuator to a Ball Valve. For information on servicing your electric or pneumatic actuator, refer to the service manual that comes with the actuator.

To attach the actuator to the valve:

1. Remove handle nut and handle
2. Sizes 1/2" through 2", attach actuator bracket to valve body using 4 bolts provided in kit
3. Place actuator coupler onto the valve stem.
4. Place actuator on the mounting bracket. (on sizes 3" and 4" valves the bracket is included on all valves as part of the body) Be sure to line up coupler with actuator. Tighten all bolts
5. Instal 4 actuator mounting bolts through bracket and into the bottom of the actuator. Tighten all bolts

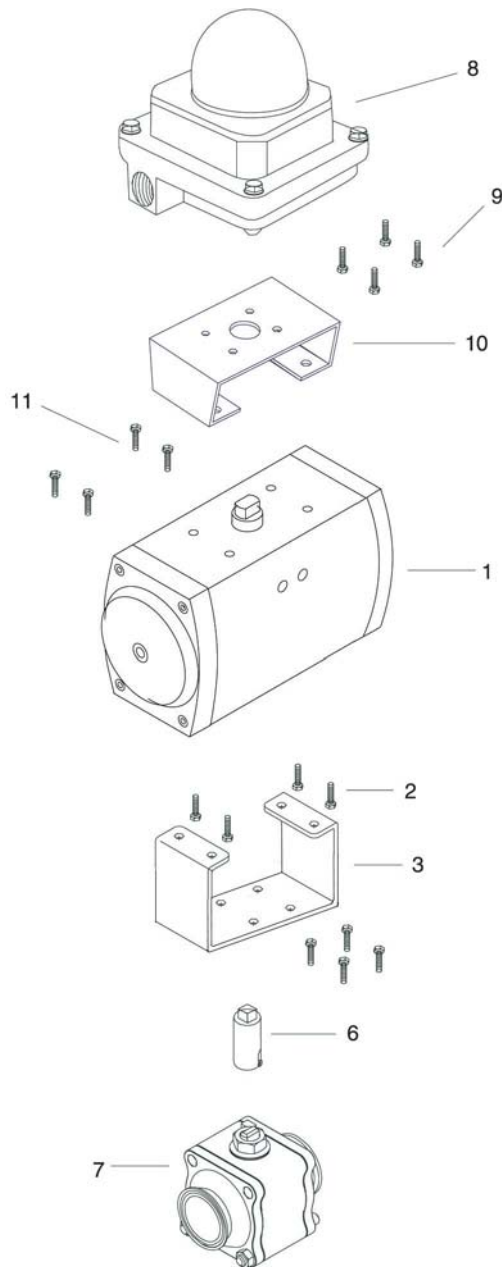

3 Technical data

All warnings in the manual are summarized on this page.

Pay special attention to the instructions below so that severe personal injury and/or damage to the valve are avoided.

3.1 Torque vs Pressure Differential

As the amount of pressure in a ball valve increases, so does the amount of torque required to open and close it. Use the charts below to determine the type of actuator, if any, that is required for your application.

PTFE Seat Material

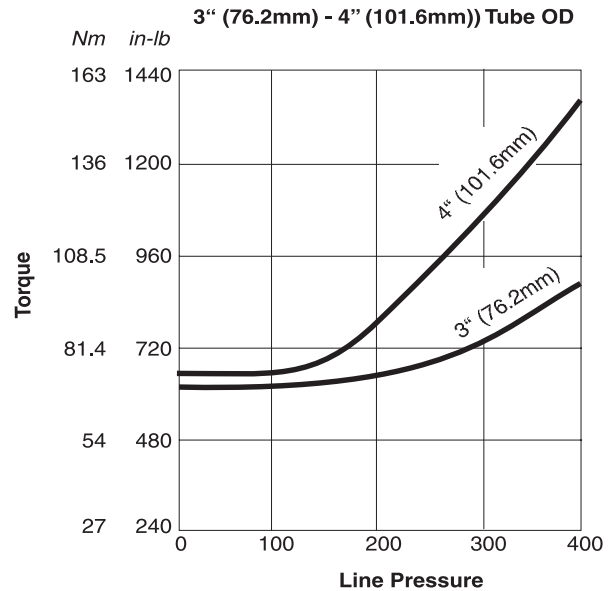
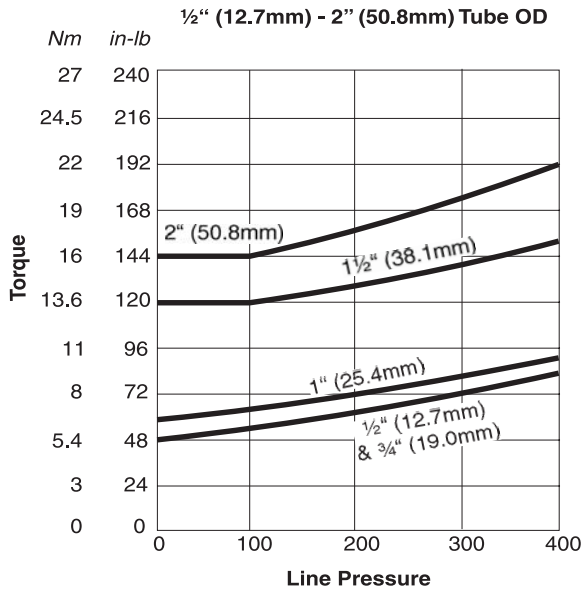

Reinforced PTFE Seat Material

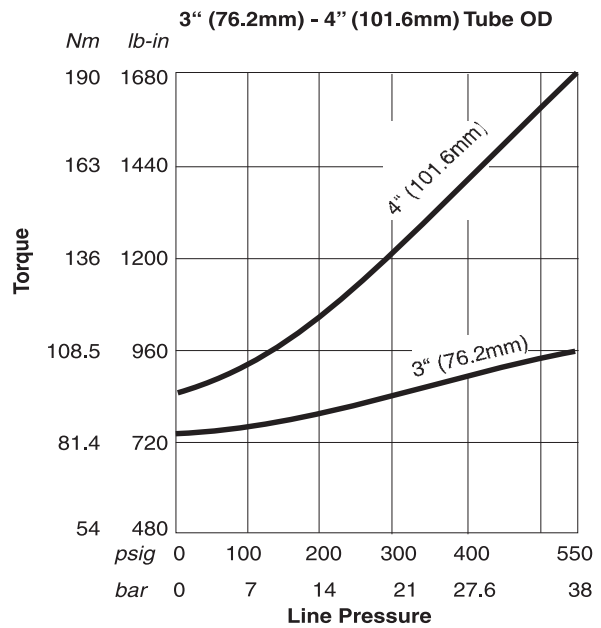
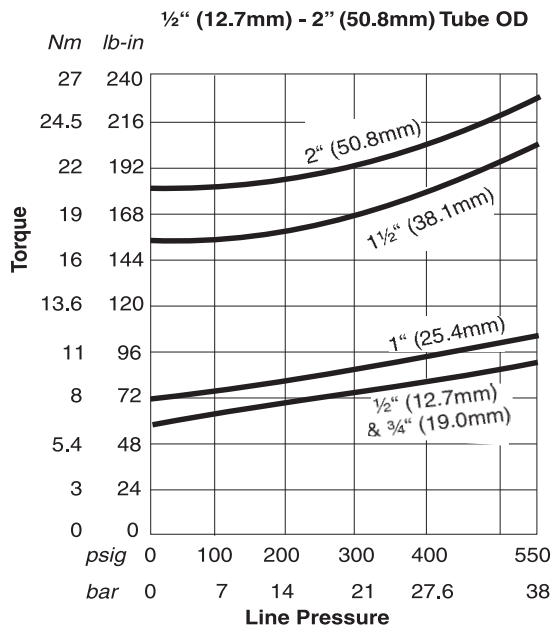

3 Technical data

All warnings in the manual are summarized on this page.

Pay special attention to the instructions below so that severe personal injury and/or damage to the valve are avoided.

4 Parts list and Service Kits

All warnings in the manual are summarized on this page.

Pay special attention to the instructions below so that severe personal injury and/or damage to the valve are avoided.

4.1 Ball Valves, UltraPure for 1/2" to 2"

Ball Valves, UltraPure for 1/2" to 2"

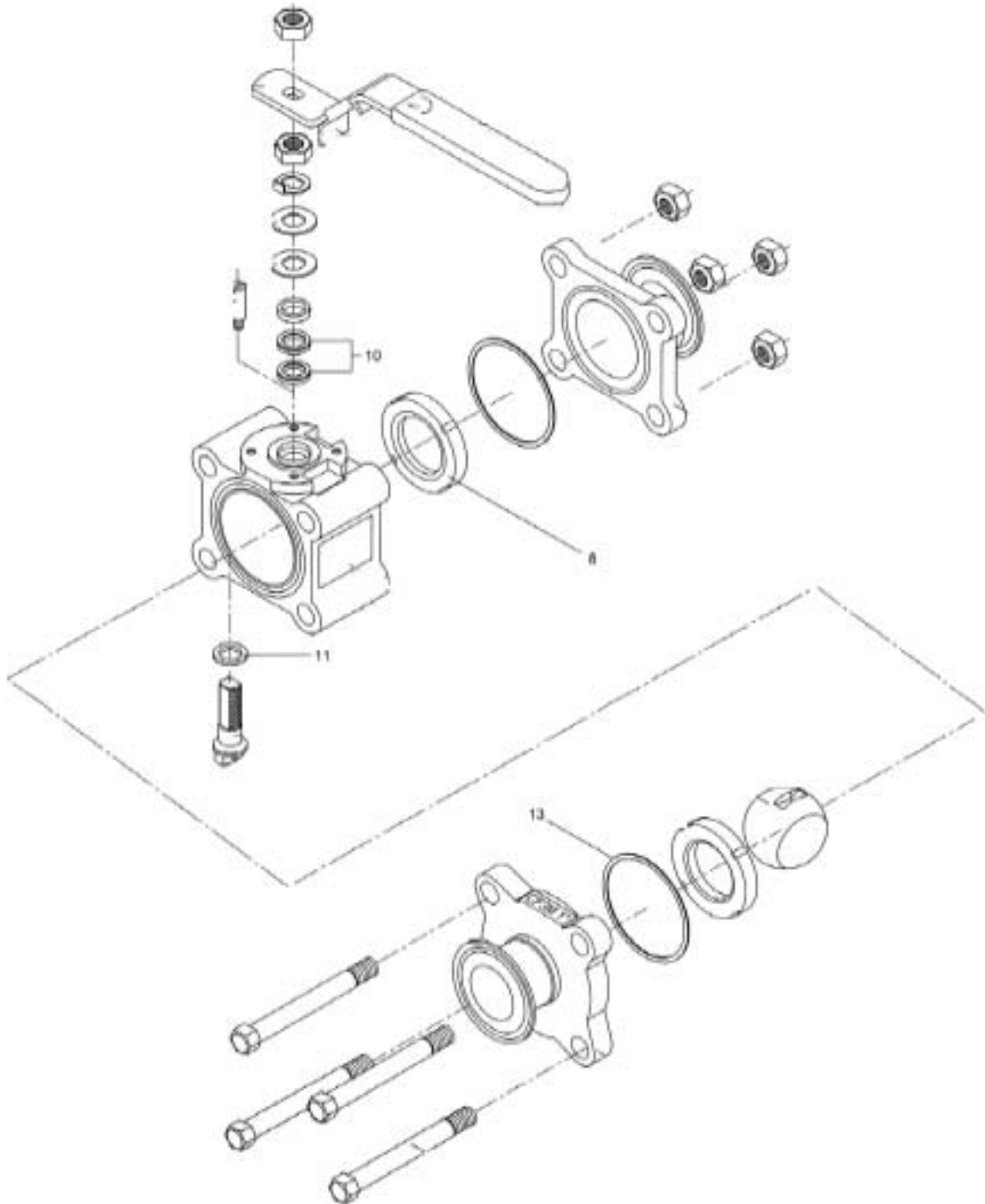

4 Parts list and Service Kits

All warnings in the manual are summarized on this page.

Pay special attention to the instructions below so that severe personal injury and/or damage to the valve are avoided.

Parts list

Pos.	Qty	Denomination
8 <input type="checkbox"/>	2	Seat, PTFE
10 <input type="checkbox"/>	2	Stem packing, PTFE
11 <input type="checkbox"/>	1	Stem seal, PTFE
13 <input type="checkbox"/>	2	Joint gasket, PTFE

Service kits

Denomination	1/2"	3/4"	1"	1 1/2"	2"
Service Kits for 1/2" to 2"					
<input type="checkbox"/> Service kits, ASME	9614051102	9614051103	9614051104	9614051105	9614051106
<input type="checkbox"/> Service kits, ISO/DIN			9614051207	9614051208	9614051209

4 Parts list and Service Kits

All warnings in the manual are summarized on this page.

Pay special attention to the instructions below so that severe personal injury and/or damage to the valve are avoided.

4.2 Ball Valves, UltraPure for 2 1/2" to 4"

Ball Valves, UltraPure for 2 1/2" to 4"

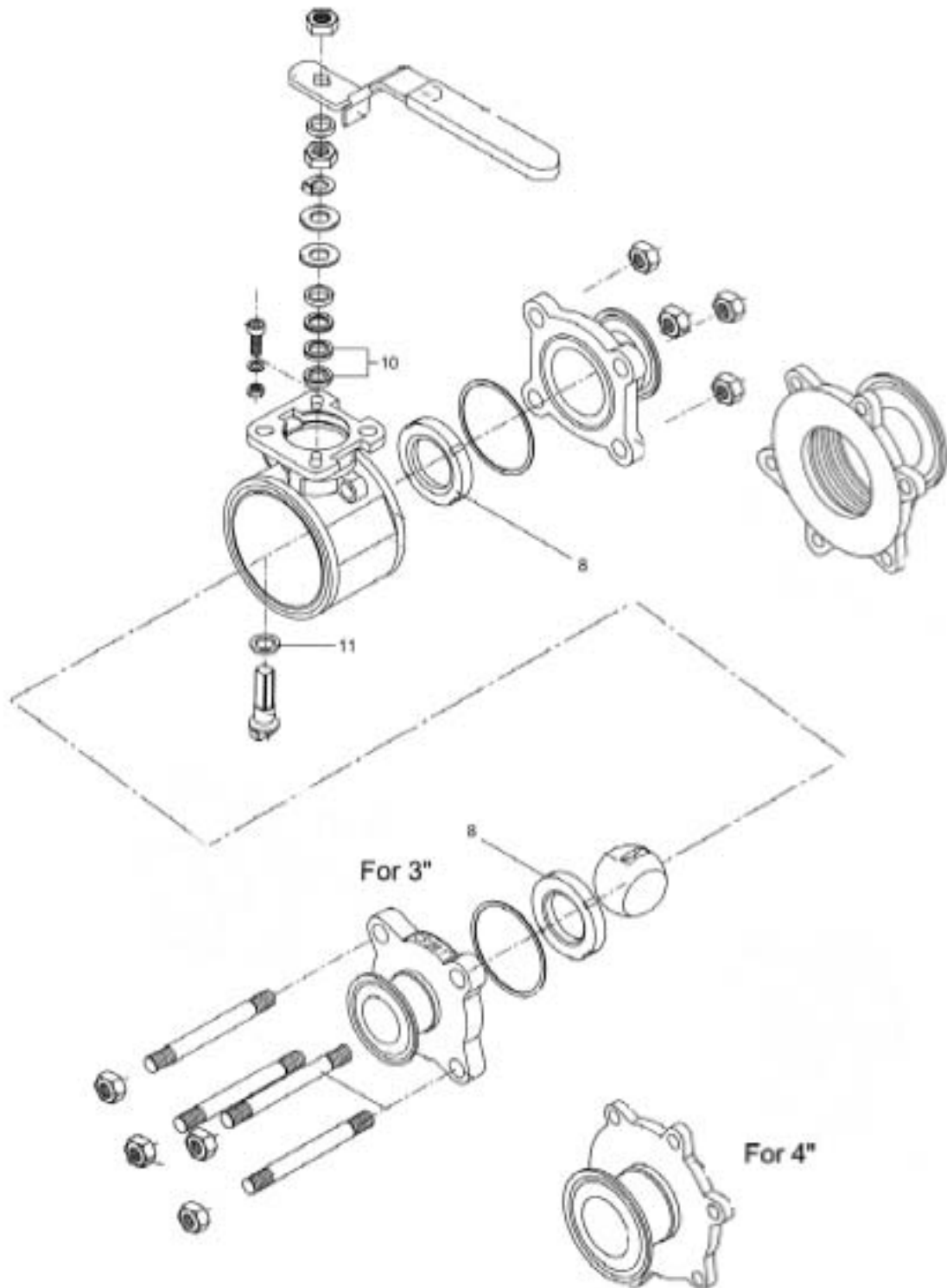

4 Parts list and Service Kits

*All warnings in the manual are summarized on this page.
Pay special attention to the instructions below so that severe personal injury and/or damage to the valve are avoided.*

Parts list

Pos.	Qty	Denomination
8 <input type="checkbox"/>	2	Seat, PTFE
10 <input type="checkbox"/>	1	V-ring packing, PTFE, set
11 <input type="checkbox"/>	1	Stem seal, PTFE
13 <input type="checkbox"/>	2	Body gasket, PFTE

Service kits

Denomination	2 1/2"	3"	4"
Service Kits for 2 1/2" to 4"			
<input type="checkbox"/> Service kits, ASME	9614051107	9614051108	9614051109
<input type="checkbox"/> Service kits, ISO/DIN	9614051210	9614051211	9614051212

4 Parts list and Service Kits

All warnings in the manual are summarized on this page.

Pay special attention to the instructions below so that severe personal injury and/or damage to the valve are avoided.

Parts list

Pos.	Qty	Denomination
8 □	2	Seat, PTFE
10 □	2	Stem packing, PTFE
11 □	1	Stem seal, PTFE
13 □	2	Joint gasket, PTFE

Service kits

Denomination	½"	¾"	1"	1½"	2"
Service Kits for 1/2" to 2"					
□ Service kits, Standard	9613830052	9613830064	9613830048	9613830044	9613830056
□ Service kits, Standard Encapsulated	9613830053	9613830065	9613830049	9613830045	9613830057
□ Service kits, Reinforced	9613830050	9613830062	9613830046	9613830042	9613830054
□ Service kits, Reinforced Encapsulated	9613830051	9613830063	9613830047	9613830043	9613830055

4 Parts list and Service Kits

All warnings in the manual are summarized on this page.

Pay special attention to the instructions below so that severe personal injury and/or damage to the valve are avoided.

4.4 Ball Valve, 5308 Series for 3" to 4"

Ball Valves, 5308 Series for 3" and 4"

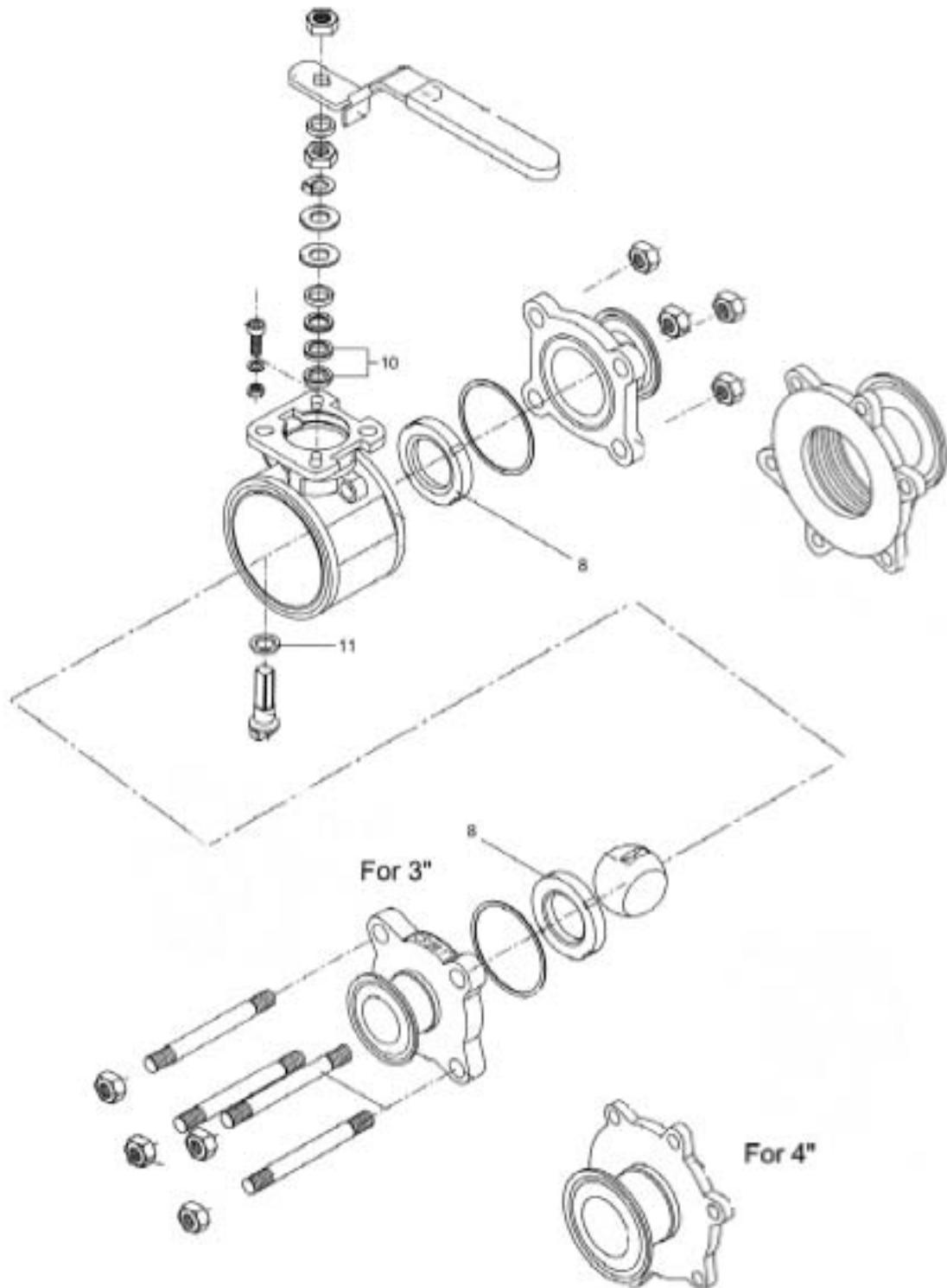

4 Parts list and Service Kits

All warnings in the manual are summarized on this page.

Pay special attention to the instructions below so that severe personal injury and/or damage to the valve are avoided.

Parts list

Pos.	Qty	Denomination
8 <input type="checkbox"/>	2	Seat, PTFE
10 <input type="checkbox"/>	1	V-ring packing, PTFE, set
11 <input type="checkbox"/>	1	Stem seal, PTFE
13 <input type="checkbox"/>	2	Body gasket, PFTE

Service kits

Denomination	3"	4"
Service Kits for 3" and 4"		
<input type="checkbox"/> Service kits, Standard	9613830060	9613830068
<input type="checkbox"/> Service kits, Standard Encapsulated	9613830061	9613830069
<input type="checkbox"/> Service kits, Reinforced	9613830058	9613830066
<input type="checkbox"/> Service kits, Reinforced Encapsulated	9613830059	9613830067

How to contact Alfa Laval

Contact details for all countries are continually updated on our website.

Please visit www.alfalaval.com to access the information directly.

© Alfa Laval Corporate AB

This document and its contents is owned by Alfa Laval Corporate AB and protected by laws governing intellectual property and thereto related rights. It is the responsibility of the user of this document to comply with all applicable intellectual property laws. Without limiting any rights related to this document, no part of this document may be copied, reproduced or transmitted in any form or by any means (electronic, mechanical, photocopying, recording, or otherwise), or for any purpose, without the expressed permission of Alfa Laval Corporate AB. Alfa Laval Corporate AB will enforce its rights related to this document to the fullest extent of the law, including the seeking of criminal prosecution.