

Mounting instructions

9611-99-5750, Indication unit for LKLA ø85, PNP, Standard pinout (ZZ0496)

Items supplied

- 1 x puck E17013
- 1 x inductive double sensor IN5225
- 2 x hexagon head screws
- 4 x washers

Wiring (PNP, Standard pin connection)

Closed: OUT +1 (A1) Pin 4

Open: OUT +2 (A2) Pin 2

Electrical design	DC PNP
Operating voltage	10...36 V DC
Output function	2 x NO
Current consumption	< 15 mA
Current rating	250 mA
Ambient temperature	-25...80 °C
Protection rating	IP 67

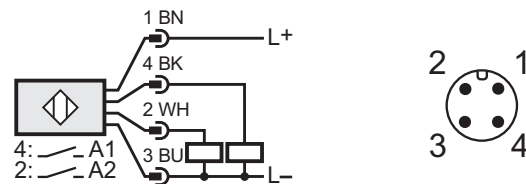

- ▶ Loosen the screws (1) and remove the angle bracket.
- ▶ Mount the puck as shown (2).
- ▶ Attach the puck and the angle bracket (3).

Pointer showing to the right: Valve is closed.
The drawing on the right shows basically an NC (Normally Closed) valve.

Puck pointer must therefore be installed to the right so that it follows the valve closed direction.

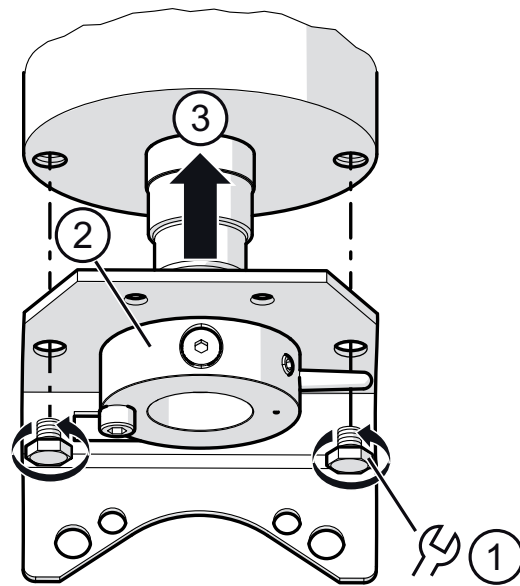

- ▶ Keep a distance of approx. 2 mm between puck and angle bracket.

Note: Most of the actuators are delivered with a coupling provided with a rim. It ensures the right distance between puck and angle bracket.

- ▶ Tighten the screws (1).
- ▶ Tighten opposite grub screws (2) on the puck, tightening torque 2 Nm.

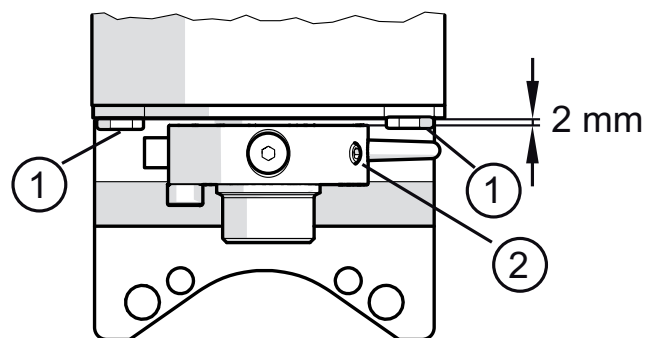

Sensor assembly

- ▶ Position sensor as shown. Align the type label properly.
- ▶ While doing this, keep the maximum distance between puck and sensor (< 1.5 mm).
- ▶ Position 2 washers under each screw head (1) and tighten the screws, tightening torque 2 Nm.

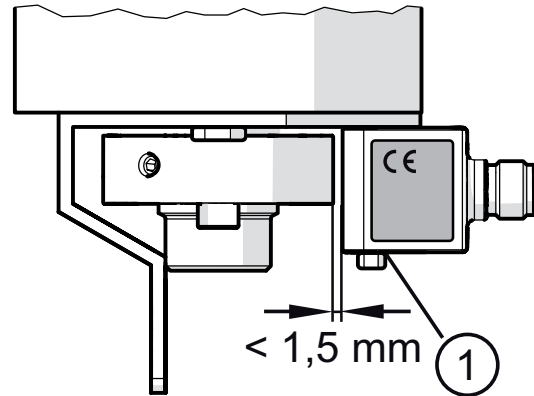

- ▶ Check the feedback for the valve states (open and closed). Indication via LED and visual pointer position.

