

Process competence boosts beverage syrup mixing flexibility and productivity

Trying to keep up with beverage trends yet remain relevant and profitable? Constant innovation is a must for beverage manufacturers.

To meet consumers' changing tastes, a global soft drink manufacturer faced increased demand for a broader array of products with a wider variety of ingredients. Thanks to Alfa Laval's broad understanding of beverage syrup room design and innovative mixing solutions, the company can soon enjoy greater process flexibility and 50% faster batch production.





Process competence and proof-of-concept trials wins customer trust

Processing liquid and dry ingredients into complex beverage syrup formulations requires production flexibility and speed. Alfa Laval demonstrated a deep understanding of the challenges faced by the global beverage manufacturer, winning the trust of key decision-makers at its central R&D and engineering departments. Trials convinced the manufacturer that changing the existing syrup room process design with innovative mixing solutions from Alfa Laval would enhance process flexibility and productivity and add customer value.

50% faster batch production time

Alfa Laval's process knowledge and commitment to enhancing productivity cut syrup processing time from two hours to one hour per batch. Replacing existing syrup room mixing technologies with the Alfa Laval Hybrid Powder Mixer in combination with the Alfa Laval Rotary Jet Mixer provides

additional hours of production time each day. The faster rate of syrup production also cuts energy costs.

Less time for maintenance

Reducing maintenance time is another example of Alfa Laval process ingenuity at work. Maintenance for the Rotary Jet Mixer requires a single service engineer working at floor level for one to two hours; in contrast, the existing large agitator requires several service engineers working an entire day on a multilevel service platform. Less downtime translates into more production uptime.

Increased worker safety

The same is true of liquid-powder mixing. Ingredient handling and dosing with the Alfa Laval Hybrid Powder Mixer occurs at floor level, resulting in easier handling and increased worker safety. This eliminates the need for workers to carry 25-kilogram bags to the upper-level platform and pour ingredients into the tank through the access port.



Alfa Laval Hybrid Powder Mixer

Hygienic dual-stage inline powder dissolution unit efficiently mixes and pumps wet and dry ingredients into a homogeneous blend.

Alfa Laval Rotary Jet Mixer

Effectively blends multiple syrup formulations and, after completion of mixing, cleans the tank – cutting mixing time, energy use and costs.

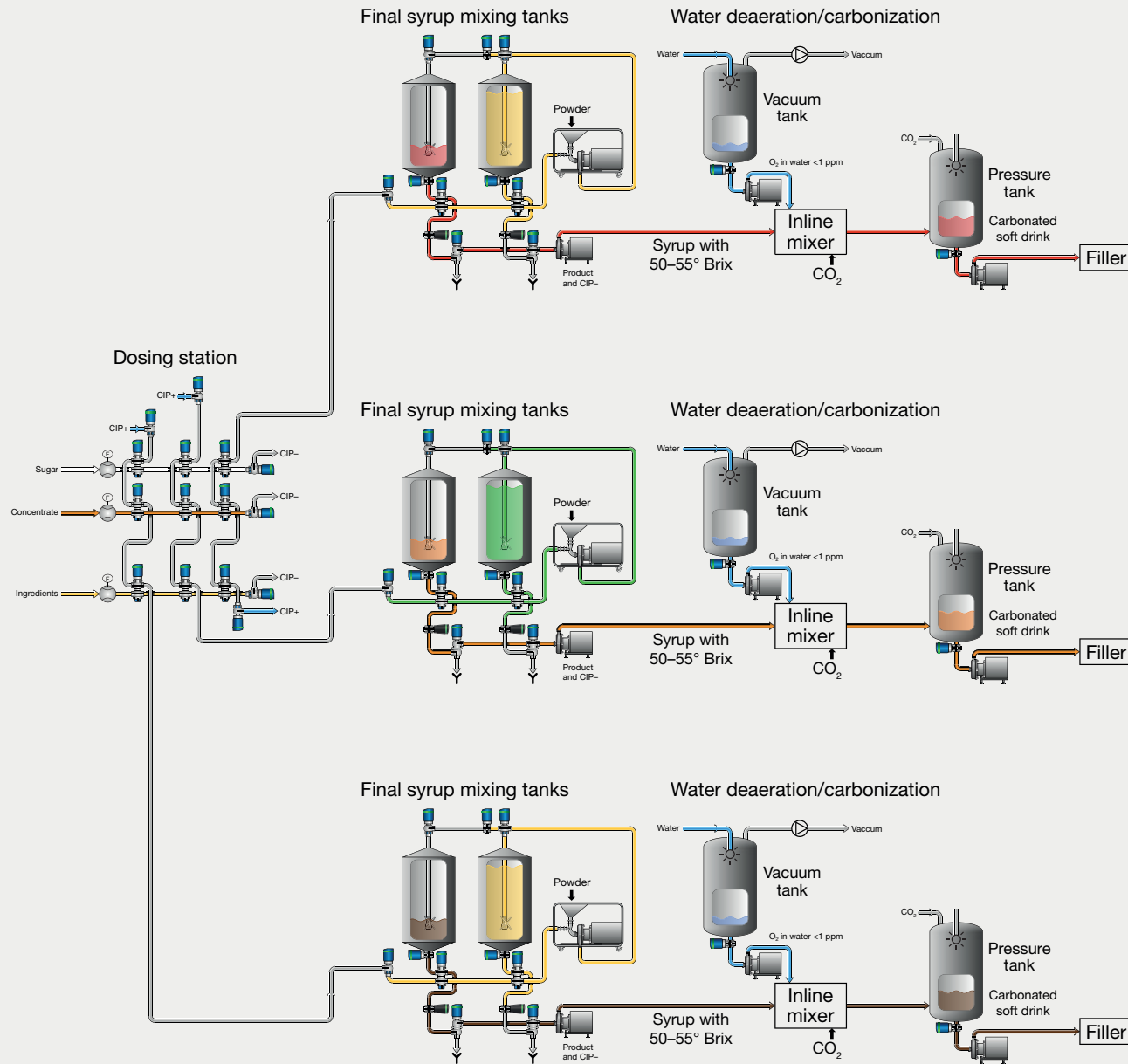

Streamlining production with mixing innovation

The unique design of the Alfa Laval Hybrid Powder Mixer together with the Rotary Jet Mixer outperforms the previous setup in the beverage syrup room, takes up less floor space and requires less investment in building service platforms. Alfa Laval teamed up and worked tirelessly with system integrators to design a mixing solution that produces more batches of complex syrup formulations – safely, quickly and efficiently.

Sustainable optimization

The next step? The company asked Alfa Laval to with its global sustainability manager to reduce emissions and introduce greater energy and water efficiency throughout the plant. A testament to Alfa Laval's process competence and ability to optimize processes and, add value and lift competitive advantage.

Trials convinced the manufacturer that changing the existing syrup room process design with innovative mixing solutions from Alfa Laval would enhance process flexibility and productivity and add customer value.



Contact Alfa Laval

Up-to-date Alfa Laval contact details for all countries are always available on our website at www.alfalaval.com