



BREW 501

Medium capacity solids-ejecting centrifuge for the brewery industry

The Alfa Laval centrifuges for breweries are available in many different sizes and configurations, each one designed and adapted to the widely varying separation tasks encountered.

A new range of Brewery separators is developed with the focus on high hygiene, low power consumption and high separation performance.

With a feed flow capacity of up to 500 hl/h (220 US gpm)* and very high solids handling capability the BREW 501 is ideal for conditions common in the brewery industry. It is a clarifier that provides automatic intermittent discharge of solids with high dry matter content thanks to the SmartEject system in the self-triggering version.

The BREW 501 is semi-hermetic and features Oxy-Stop, which is a hydrohermetic seal for minimal oxygen pick-up of the clarified liquid.

* Actual capacity depends on application

Applications

The BREW 501 is typically used in the following steps in the brewing process:

- Pre-clarification
- Green beer separation
- Hot wort separation

Because the BREW 501 is designed to be flexible, it performs equally well in the different conditions met with in each of these processes.

Standard design

All metallic parts that come in contact with the process liquid are made of high-grade stainless steel. Liquid-wetted rubber gaskets are made of FDA approved nitrile rubber. The frame upper part and the hood are cooled with water, which reduces



BREW 501 complete with motor

temperature increase of the process medium to a minimum and at the same time acts as a sound dampener. The centrifuge is equipped with sensors for monitoring bowl speed and vibration level. Flushing takes place inside, above and under the bowl, in the cyclone and in the Oxy-Stop seal.

Special features

The BREW 501 is based on a unique, semi-hermetic design concept. The hermetic, bottom-fed inlet ensures a gentle acceleration of the beer up to full bowl speed. This minimizes splitting of shear-sensitive protein particles, maximizing separation performance. The inlet principle used means a power saving of up to 30%.

The discharge volume is adjustable. Together with the triggering system, based on turbidity of the separated liquid, it ensures discharge of solids with high dry matter content, thus minimising product losses.

The separator has a hydro-hermetic Oxy-stop seal, which minimises oxygen pick-up and is equipped with a built-in paring disc for the separated product, eliminating the need for an external pump.

The bowl casing is jacketed for cooling and sound dampening. The cooling of the solids collecting chute and the cyclone ensures against burning-on of proteins.

The sliding bowl bottom is fitted with an easily exchangeable erosion liner for protection against possible abrasive solids.

The presence of a frequency inverter in the VFD system gives a number of advantages, including low starting current, and a short-time power supply at external power failure.

Operating principles

The feed is introduced into the rotating centrifuge bowl from the bottom via the hollow bowl spindle (1) and accelerated in a distributor (2) before entering the disc stack (3). The separation takes place between the discs.

The liquid phase moves towards the centre of the bowl where it is pumped out under pressure by means of a built-in paring disc (4). The heavier solids phase is collected at the periphery of the bowl where it is discharged intermittently via the centrifuge cyclone.

The solids are discharged by a hydraulic system below the separation space in the bowl, which at certain intervals forces the sliding bowl bottom (5) to drop down thus opening the solids ports (6) at the periphery of the bowl. The triggering system functions by outlet turbidity and/or timer.

Basic equipment

Centrifuge with motor and frequency inverter, speed sensor, vibration switch, vibration-dampening feet, set of tools and standard set of spares.

Options

The disc stacks are available with several different diameters, giving different solids space volumes, and with two different disc spacings.

Optional extras

Additionally, the BREW 501 is available with a cover interlocking kit to make it impossible to start the centrifuge unless it is properly assembled, and additional service kits.

The BREW 501 can be delivered as a complete fully automated system, including valve modules for process and service liquids, starter and control system. The system can also include Capacity control, an automatic flow regulation function to adapt to changing solids content in the feed.

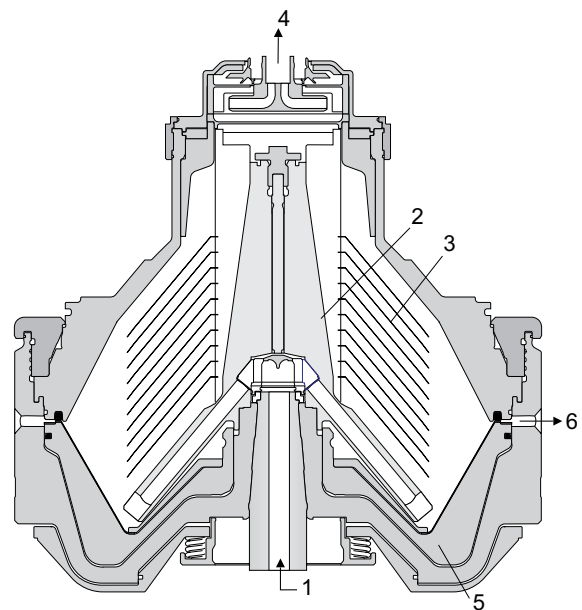

Typical semi-hermetic bowl for a solids ejecting clarifying centrifuge. The details illustrated do not necessarily correspond to the centrifuge described.

Material data

Bowl body, hood and lock ring	s.s. 1.4418
Solids cover and frame hood	s.s. 1.4401 UNS 31600
Bottom frame	Cast iron
Inlet and outlet	stainless steel 1.4401 UNS 31600
Gaskets and O-rings	Nitrile rubber ¹⁾

¹⁾ In accordance with FDA CFR 21§177.2600

Shipping data (approximate)

Separator incl. bowl and motor	2,550 kg (5,600 lbs)
Bowl	1,150 kg (2,500 lbs)
Gross weight	2,800 kg (6,200 lbs)
Volume	10 m ³ (350 cuft)

Technical specifications

Hydraulic capacity	500hl/h (220 US gpm)
Bowl speed	4,300 rpm
Sludge space volume	33 l (9 US gal)
Motor power installed	42 kW (55 HP)
Feed temperature range	-5° C-100° C (23–212°F)
Inlet pressure at 50m ³ /h at inlet flange	120 kPa (17 psig)
Sound pressure	78 dB(A) ¹⁾
Overhead hoist lifting capacity	min. 1,160 kg (2,600 lbs)

¹⁾ In compliance with EN ISO 3744

Dimensions

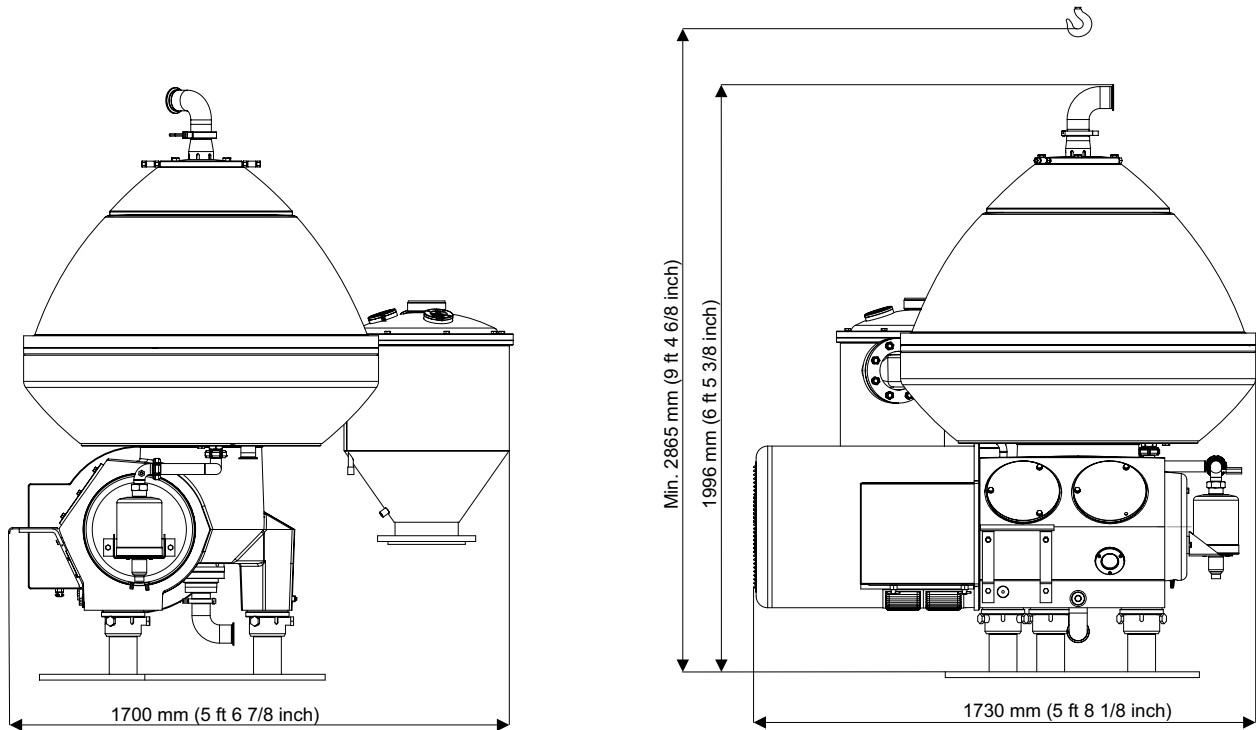

How to contact Alfa Laval

Up-to-date Alfa Laval contact details for all countries are always available on our website at www.alfalaval.com.