



BREW 2000

High capacity solids-ejecting centrifuge for the brewery industry

The Alfa Laval separator centrifuges for breweries are available in many different sizes and configurations, each one designed and adapted to the widely varying separation tasks encountered. A high feed flow capacity of up to 750 hl/h** and high solids handling capability meet the tough conditions encountered within the brewery industry. The BREW 2000 is a clarifier that provides intermittent self-triggered discharge of solids in a very dry state and features a combination of high g-force, a high standard of hygiene and automated operation. The BREW 2000 is also equipped with Oxy-Stop, which is a hydrohermetic seal for minimal oxygen pick-up of the clarified liquid.

** actual capacity depends on the application

Applications

The BREW 2000 is used for removing suspended solids with a particle size of 0.5–500 µm. The solids content in the feed is normally in the range of 0.1–10 % by volume depending on the specific operation involved, but may also be higher.

Standard design

All metallic parts in contact with the process liquid are made of high-grade stainless steel. Liquid-wetted rubber gaskets are made of nitrile rubber or food grade EPDM rubber. The centrifuge is equipped with sensors for monitoring vibration level, oil pressure and the temperatures of the main bearing and motor winding. Flushing takes place inside, above and under the bowl, in the cyclone and in the Oxy-Stop seal. The electric motor is of the controlled torque type or of a standard type with variable frequency drive.

Special features

In the BREW 2000, the discharge volume is adjustable. The separator is equipped with a built-in paring disc for the liquid phase, eliminating the need for an external pump. The top part of the frame, the frame hood and the cyclone are jacketed for cooling and sound dampening. The bearings and the lubrication of the drive system are integrated with the spindle in a cartridge, which makes service significantly easier. The bowl bottom is fitted with an easily exchangeable erosion liner for protection against possible abrasive solids.

Basic equipment

Centrifuge with motor, set of tools, speed sensor, vibration switch, vibration dampening feet, foundation plate and standard set of spares.



The complete BREW 2000 with motor

Options

The centrifuge is available with three different paring discs for low and high capacity, and four disc stacks with different diameters and disc spacings.

Optional extras

The BREW 2000 is available with the following optional extras: a set of special tools, cover interlocking kit to make it impossible to start the centrifuge unless it is properly assembled, and service kits. The BREW 2000 can be delivered as a complete system, including valve modules for process and service liquids, starter and control system.

Material data

Bowl body, hood and lock ring	s.s. 1.4418
Solids cover and frame hood	s.s. 1.4401 UNS 31600
Frame bottom part	cast grey iron
Inlet and outlet parts	s.s. mostly 1.4401 UNS 31600
Gaskets and O-rings	Nitrile rubber or food grade EPDM ¹⁾

¹⁾ In accordance with FDA 21 CFR 177.260

Operating principles

The feed is introduced into the rotating centrifuge bowl from the top via a stationary inlet pipe (1) and accelerated in a distributor (2) before entering the disc stack (3). The separation takes place between the discs. The liquid phase moves towards the centre of the bowl where it is pumped out under pressure by means of a built-in paring disc (4). The heavier solids phase is collected at the periphery of the bowl where it is discharged intermittently via the centrifuge cyclone. The solids are discharged by a hydraulic system below the separation space in the bowl, which at certain intervals forces the sliding bowl bottom (5) to drop down thus opening the solids ports (6) at the periphery of the bowl. The self-triggering system functions as follows; a sensing gas is introduced via the top (7) into the sensing chamber (8). When the accumulated solids reach the outer periphery of the sediment indicating disc (9), the pressure in the sensing gas line changes. This pressure change acts as a trigger via an optional control system.

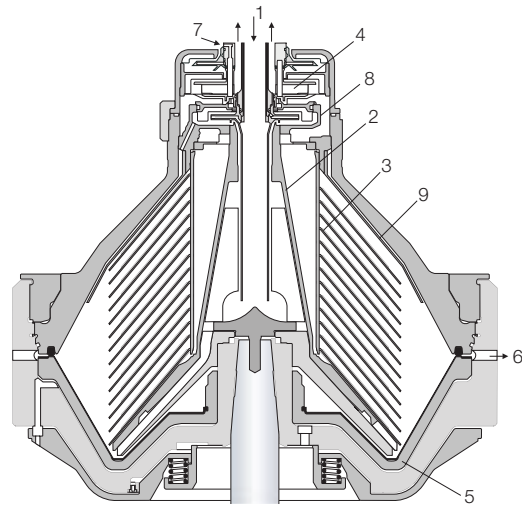

Typical bowl for self-triggering solids-ejecting clarifier centrifuge. The details illustrated do not necessarily correspond to the centrifuge described.

Utilities consumption

Electric power at 40 m ³ /h	18-75 kW ¹⁾
Operating liquid for solids discharge	10 - 100 l/h +1.5 l/discharge
Flushing liquid, max per discharge	35 l/discharge ²⁾
Cooling liquid for lubricating oil	100 l/h
Cooling water for cyclone	300 l/h
Cooling water for frame top part and hood	300 l/h
Gas for self-triggering	max. 300 NI/h
Instrument air	approx. 5 NI/discharge
CO ₂ to liquid seal.	300 NI/h ³⁾
Water to liquid seal.	10 l/h ³⁾

¹⁾ Actual consumption increases with throughput capacity, etc.

²⁾ Only used if required by process

³⁾ Sealing medium and consumption depends on application

Dimensions

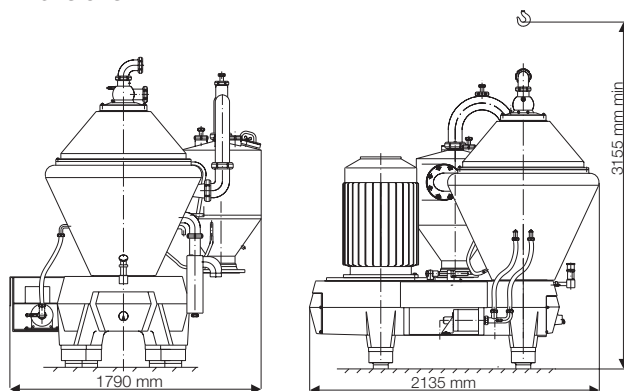

Technical specification

Throughput capacity	750 hl/h ¹⁾
Solids handling capacity	1950 l/h ²⁾
Bowl speed	4800 rpm
Motor speed synchronous 50/60 Hz	3000/3600 rpm
Centrifugal force inside bowl	max. 8296 g
Bowl volume	59 l
Sludge space volume	max. 33 l
Installed motor power	75 kW
Starting time	9 min
Stopping time, at 300 kPa brake pressure	17-25 min
Feed temperature range	-5 - 100 °C
Feed inlet pressure required at inlet flange	max. 350 kPa
Liquid outlet pressure at outlet flange	normally 500 kPa
Sound pressure	79 dB(A) ³⁾
Overhead hoist lifting capacity, min	1900 kg

¹⁾ Valid for large paring disc. Actual throughput capacity depends on amount and type of solids in the feed, viscosity and required degree of clarification.

²⁾ Wet solids. Actual amount depends on discharge volume and application

³⁾ According to ISO 3744

Shipping data (approximate)

Centrifuge including bowl and motor	2800 kg
Bowl weight	885 kg
Gross weight approx.	3000 kg
Volume	10 m ³

How to contact Alfa Laval

Up-to-date Alfa Laval contact details for all countries are always available on our website at www.alfalaval.com