



# High efficiency with a small footprint

## Alfa Laval U-Turn MK15 – plug'n'play module for flooded ammonia

### Turn to efficiency

U-Turn is a liquid separator especially designed for use with plate heat exchangers in ammonia applications. The module – including the separator and plate heat exchanger (PHE) ensures minimum pressure drop losses and maximum energy efficiency.

Plate heat exchangers from Alfa Laval can operate with the smallest LMTD (Logarithmic Mean Temperature Difference) as evaporators. To ensure this efficiency is not lost from a liquid column that is too small or large, or due to incorrect pressure drop, Alfa Laval has developed the U-Turn separator. The module provides an effective and compact installation with less vertical rise and smaller overall dimensions than any other solution. All ammonia connections are grouped on the same side which allows the module to be installed in close proximity to walls or on the perimeter of a main skid.

### U-Turn in action

Alfa Laval U-Turn is designed to utilize the very best from Alfa Laval's plate heat exchanger technology. Installed above the plate heat exchanger, the self-contained U-Turn can be easily mounted onto the compatible MK15. It can cover ammonia capacities from 200 to 1400 kW at 0°C evaporation temperature and from 50 to 500 kW at -40°C evaporation temperature.

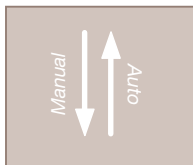
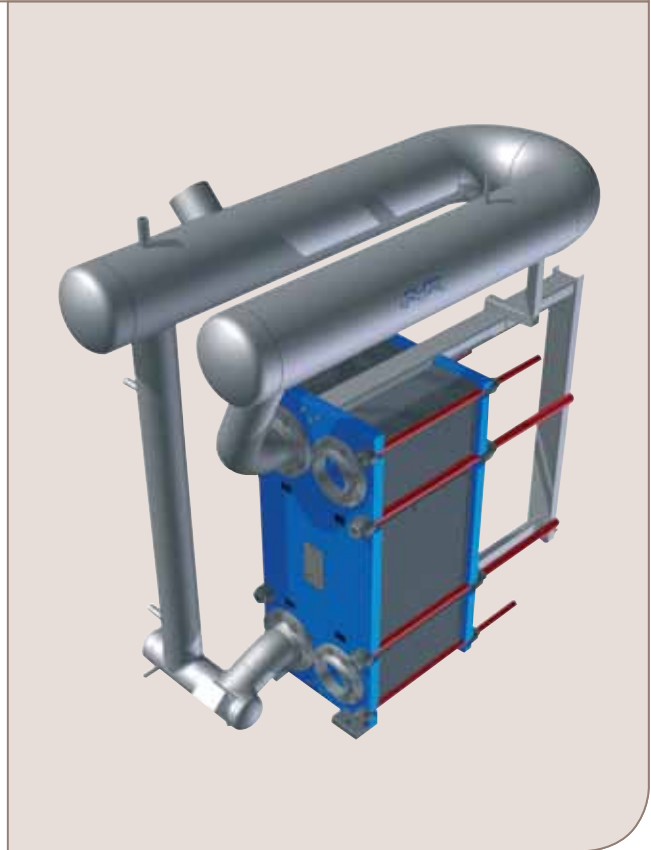

**Nozzles for preferred oil drain method**  
– various oil drainage options



**Predefined liquid level and charge**  
– information to run U-Turn module at peak performance



**Check valve for start-up flow control**  
– immediate safety operation



**Self-contained unit**  
– easy installation and full access, no skids or frame required

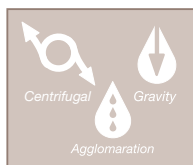

**Multiple separation methods** – enhanced separation efficiency and extremely low ammonia charge

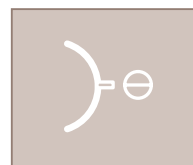

**Nozzles for regulation and control devices**  
– allow the option of preferred control system

# U-Turn liquid separator for flooded ammonia evaporator with plate heat exchanger MK15

Capacity selection table														
Evaporating temperature	[C°]	One-stage cycle								Part of two-stage cycle				Length of carrying bar
		+10		0		-10		-20		-30		-40		
Condensing temperature	[C°]	+40	+30	+40	+30	+40	+30	+40	+30	+5	-10	+5	-10	
Model UL/UR-12-6C-MK15-12-PED	[kW]	930	980	740	780	575	600	435	455	365	385	250	265	1200
Model UL/UR-12-6C-MK15-15-PED	[kW]	1165	1230	935	975	725	760	545	570	460	485	315	335	1500
Model UL/UR-12-6C-MK15-18-PED	[kW]	1410	1480	1125	1180	850	915	655	685	550	585	380	405	1800
Model UL/UR-12-6C-MK15-24-PED	[kW]	1880	1880	1453	1453	1165	1220	880	920	740	780	510	545	2400

Separator capacities vs. gas- and reintraintment velocities									
Evaporating temperature	[C°]	+10	0	-10	-20	-30	-40	Max. number of cassettes 0.5 mm *	Max. number of cassettes 0.6mm *
Condensing temperature	[C°]	+40	+40	+40	+40	+40	+40		
Model UL/UR-12-6C-MK15-12-PED									
Max. allowable capacity	[kW]	930	740	575	435	365	250	76/68	74/67
Gas velocity at max. capacity	[m/s]	2,3	2,6	2,9	3,3	3,8	4,3		
Reintrainment velocity at max. capacity	[m/s]	7	8,5	10,5	13,1	16,5	21,2		
Model UL/UR-12-6C-MK15-15-PED									
Max. allowable capacity	[kW]	1165	935	730	545	460	315	104/97	102/95
Gas velocity at max. capacity	[m/s]	2,9	3,3	3,7	4,2	4,7	5,4		
Reintrainment velocity at max. capacity	[m/s]	7	8,5	10,5	13,1	16,5	21,2		
Model UL/UR-12-6C-MK15-18-PED									
Max. allowable capacity	[kW]	1410	1125	875	655	550	380	133/126	131/124
Gas velocity at max. capacity	[m/s]	3,5	3,9	4,5	5,1	5,7	6,5		
Reintrainment velocity at max. capacity	[m/s]	7	8,5	10,5	13,1	16,5	21,2		
Model UL/UR-12-6C-MK15-24-PED									
Max. allowable capacity	[kW]	1850	1453	1170	880	740	510	191/184	187/180
Gas velocity at max. capacity	[m/s]	4,2	5,3	5,9	6,7	7,6	8,7		
Reintrainment velocity at max. capacity	[m/s]	7	8,5	10,5	13,1	16,5	21,2		

\*0-holed/4-holed pressure plate

Weights and volumes						
	Model		UL/UR-12-6C-MK15-12	UL/UR-12-6C-MK15-15	UL/UR-12-6C-MK15-18	UL/UR-12-6C-MK15-24
Number of cassettes	Maximum		73	102	130	182
Weights	Frame	[kg]	961	982	1003	1045
	Stainless steel (AISI 304/AISI 316) 0.5 mm cassette, per cassette		4.73			
	Stainless steel (AISI 304/AISI 316) 0.6 mm cassette, per cassette		5.64			
	Stack of cassettes, at max. number		478	667	850	1190
	U-Turn separator, max.		493	520	544	595
	Total plate heat-exchanger and U-Turn separator, max.	971	1187	1394	1785	
Volumes on refrigerant side	Channel volume, per cassette	[dm3]	1,27			
	Channel volume, at max. number of cassettes		93	130	165	231
	U-Turn separator volume		269	348	412	465
	Total plate heat-exchanger and U-Turn separator volume		362	478	577	696
Oil volume	Oil pot volume	[dm3]	12	12	12	12
Surfaces	Exposed surface plate heat-exchanger	[m2]	3,9	4,6	5,4	6,8
	Exposed surface U-Turn separator		4,3	5,7	6,5	6,7
	Total surface		8,2	10,3	11,9	13,5

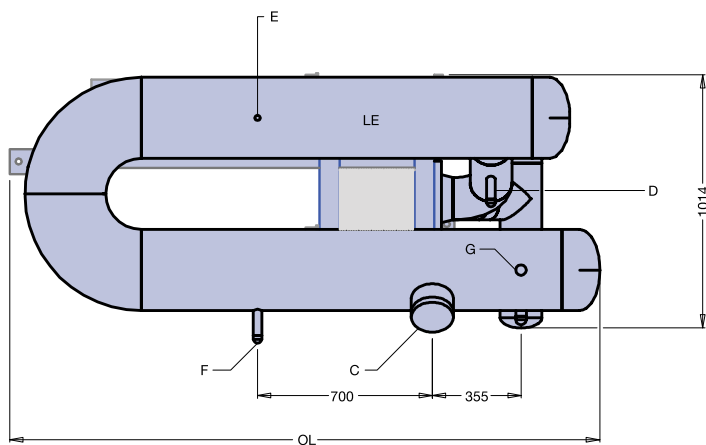
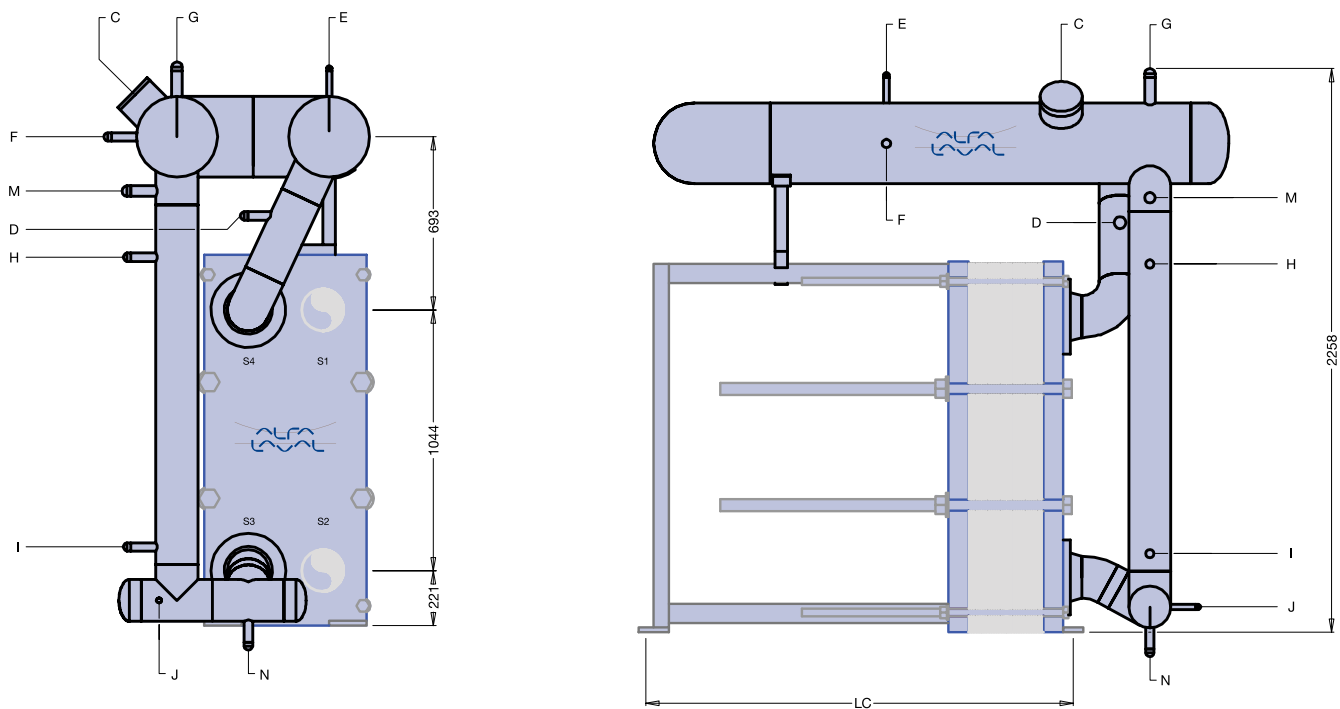

Measurements in mm. Authorized drawing at order.

Nozzle dimensions										
Nozzle	C	D	E	F	G	H	I	J	M	N
Function	Suction gas	Liquid feed	Gauge	Safety relief valve	Liquid level	Liquid level	Liquid level	Optional oil drain	Liquid level high level trip out	Oil drain optional
Dim. [mm]	ø168,3	ø48,3	ø21,3	ø33,7	ø42,4	ø33,7	ø33,7	ø21,3	ø42,4	ø33,7
Type	BW	BW	BW	BW	BW	BW	BW	BW	BW	BW

Main dimensions		
LC Length of carrying bar [mm]	OL Overall length [mm]	LE Efficient length of separation [mm]
1200	2064	3265
1500	2364	3867
1800	2664	4490
2400	3264	5664

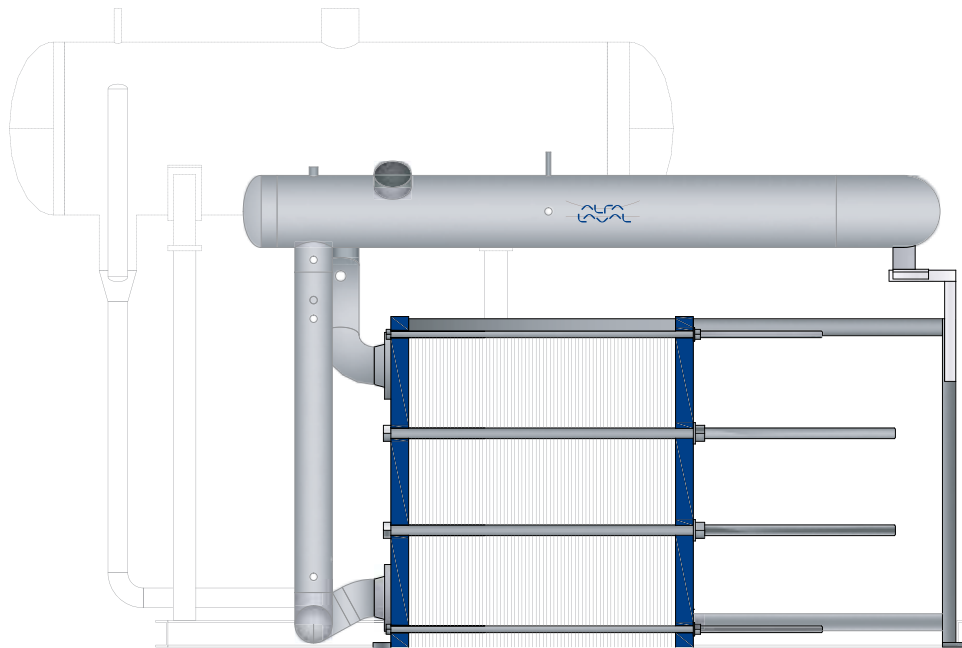

The U-Turn evaporator module design versus traditional separator design.

#### The design that gives the U-Turn its name

- Compact dimensions
- Shorter height and length – packages can be installed onsite without dismantling
- Effective length ( $L_{eff}$ ) of U-Turn follows the plate heat exchanger carrying bar length
- Three-point support – the U-Turn separator is supported entirely by the PHE, no additional support is needed.
- Easy maintenance – both sides of PHE fully accessible.
- All ammonia connections access the same side – easy installation
- Integrated oil drain
- Stainless steel – corrosion resistant and no need of surface treatment
- Available in left or right side configuration.

#### Ready to install

- Short delivery time due to standardization
- Fully functional module from one supplier
- Front plate gives easy access to primary/secondary connections
- CE-stamped and according to PED (Pressure Equipment Directive).

#### Opening a new chapter in evaporation

- Efficient separation – due to the use of four different separation methods
- Short vertical ammonia driving columns, allowing small temperature approaches and high system efficiency.
- Reduced hold-up/low charge, extremely low refrigerant charges
- Sliding support: allowing thermal expansion, ensuring no thermal tensions build up
- Significant oil pot volume in standard execution enough for manual drain
- Separation based on droplet size 0.15 mm
- Margin for separation is 25% plus one nominal diameter
- Maximum separation gas velocity is restricted to 60% of the re-entrainment velocity, avoiding liquid brought back to the gas flow
- Extra safety margin from 180° U-bend.



ERC00388EN 1204

Alfa Laval reserves the right to change specifications without prior notification.

#### How to contact Alfa Laval

Up-to-date Alfa Laval contact details for all countries are always available on our website at [www.alfalaval.com](http://www.alfalaval.com).