



High efficiency with a small footprint

Alfa Laval U-Turn M10 – plug'n'play module for flooded ammonia

Turn to efficiency

U-Turn is a liquid separator especially designed for use with plate heat exchangers in ammonia applications. The module – including the separator and plate heat exchanger (PHE) ensures minimum pressure drop losses and maximum energy efficiency.

Plate heat exchangers from Alfa Laval can operate with the smallest LMTD (Logarithmic Mean Temperature Difference) as evaporators. To ensure this efficiency is not lost from a liquid column that is too small or large, or due to incorrect pressure drop, Alfa Laval has developed the U-Turn separator. The module provides an effective and compact installation with less vertical rise and smaller overall dimensions than any other solution. All ammonia connections are grouped on the same side which allows the module to be installed in close proximity to walls or on the perimeter of a main skid.

U-Turn in action

Alfa Laval U-Turn is designed to utilize the very best from Alfa Laval's plate heat exchanger technology. Installed above the plate heat exchanger, the self-contained U-Turn can be easily mounted onto the compatible M10. It can cover ammonia capacities from 200 to 1400 kW at 0°C evaporation temperature and from 50 to 500 kW at -40°C evaporation temperature.

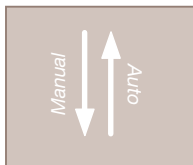
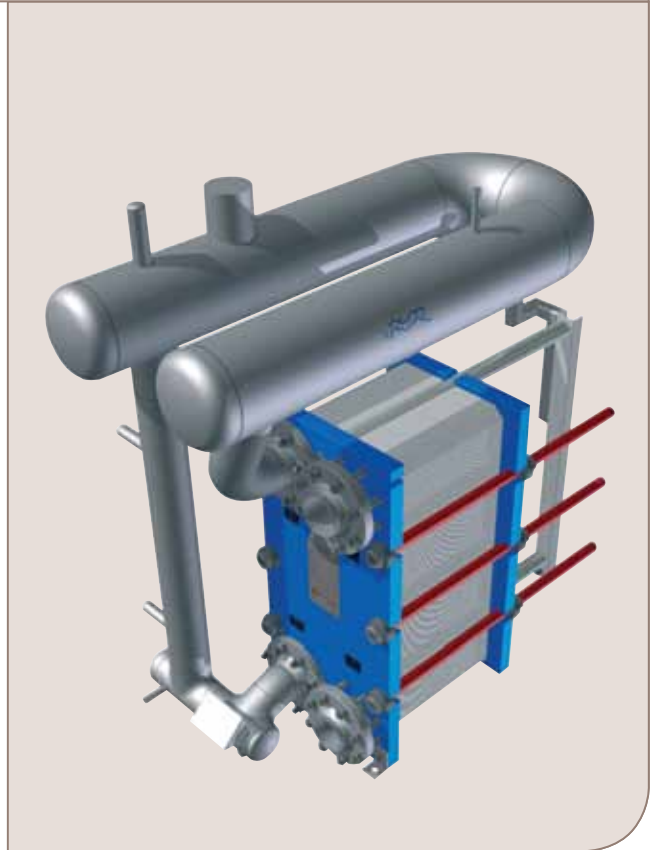

Nozzles for preferred oil drain method
– various oil drainage options



Predefined liquid level and charge
– information to run U-Turn module at peak performance



Check valve for start-up flow control
– immediate safety operation



Self-contained unit
– easy installation and full access, no skids or frame required

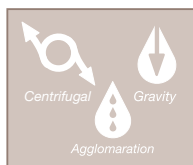

Multiple separation methods – enhanced separation efficiency and extremely low ammonia charge

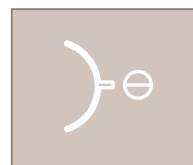

Nozzles for regulation and control devices
– allow the option of preferred control system

U-Turn liquid separator for flooded ammonia evaporator with plate heat exchanger M10

Capacity selection table														
Evaporating temperature	[C°]	One-stage cycle								Part of two-stage cycle				Length of carrying bar
		+10		0		-10		-20		-30		-40		
Condensing temperature	[C°]	+40	+30	+40	+30	+40	+30	+40	+30	+5	-10	+5	-10	
Model UR/UL-8-4C-M10-9-PED	[kW]	470	490	375	395	290	305	220	225	185	195	125	133	900
Model UR/UL-8-4C-M10-12-PED	[kW]	620	655	495	520	380	400	290	305	245	270	170	180	1200
Model UR/UL-8-4C-M10-16-PED	[kW]	700	655	600	630	510	535	385	405	320	335	223	235	1600

Separator capacities vs. gas- and reintraintment velocities										
Evaporating temperature	[C°]	+10	0	-10	-20	-30	-40	Max. number of cassettes 0.5 mm	Max. number of cassettes 0.6 mm	
Condensing temperature	[C°]	+40	+40	+40	+40	+40	+40			
Model UR/UL-8-4C-M10-9-PED										
Max. allowable capacity	[kW]	470	375	290	220	185	127	68	67	
Gas velocity at max. capacity	[m/s]	2,9	3,2	3,7	4,2	4,7	5,3			
Reintrainment velocity at max. capacity	[m/s]	7	8,5	10,5	13,1	16,5	21,2			
Model UR/UL-8-4C-M10-12-PED										
Max. allowable capacity	[kW]	620	495	380	290	245	170	114	111	
Gas velocity at max. capacity	[m/s]	3,8	4,3	4,8	5,5	6,3	7,1			
Reintrainment velocity at max. capacity	[m/s]	7	8,5	10,5	13,1	16,5	21,2			
Model UR/UL-8-4C-M10-16-PED										
Max. allowable capacity	[kW]	700	600	510	385	320	223	159	155	
Gas velocity at max. capacity	[m/s]	4,3	5,2	6,4	7,3	8,2	9,3			
Reintrainment velocity at max. capacity	[m/s]	7	8,5	10,5	13,1	16,5	21,2			

Weights and volumes					
	Model		UR/UL-8-4C-M10-9	UR/UL-8-4C-M10-12	UR/UL-8-4C-M10-16
Number of cassettes	Maximum		73	102	130
Weights	Frame	[kg]	359	392	404
	Stainless steel (AISI 304/AISI 316) 0.5 mm cassette, per cassette		2.50		
	Stainless steel (AISI 304/AISI 316) 0.6 mm cassette, per cassette		3.00		
	Stack of cassettes, at max. number		285	396	495
	U-Turn separator, max.		68	82	90
	Total plate heat-exchanger and U-Turn separator, max.		715	867	989
Volumes on refrigerant side	Channel volume, per cassette	[dm3]	0,63		
	Channel volume, at max. number of cassettes		60	83	104
	U-Turn separator volume		112	131	156
	Total plate heat-exchanger and U-Turn separator volume		172	214	260
Oil volume	Oil pot volume	[dm3]	5	5	5
Surfaces	Exposed surface plate heat-exchanger	[m2]	2,5	3	3,6
	Exposed surface U-Turn separator		2,8	3,2	4,8
	Total surface		5,3	6,2	8,4

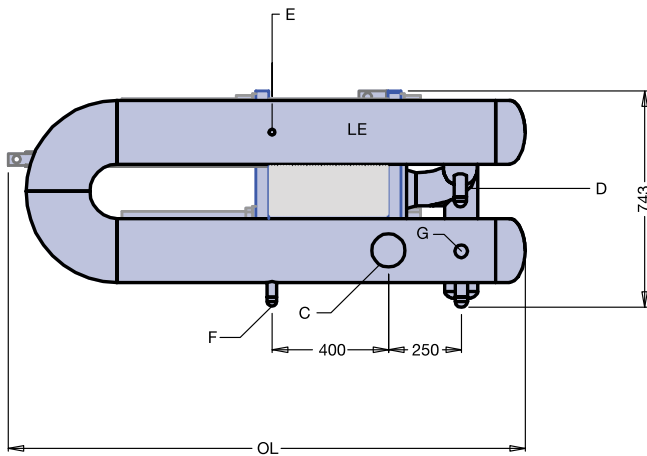
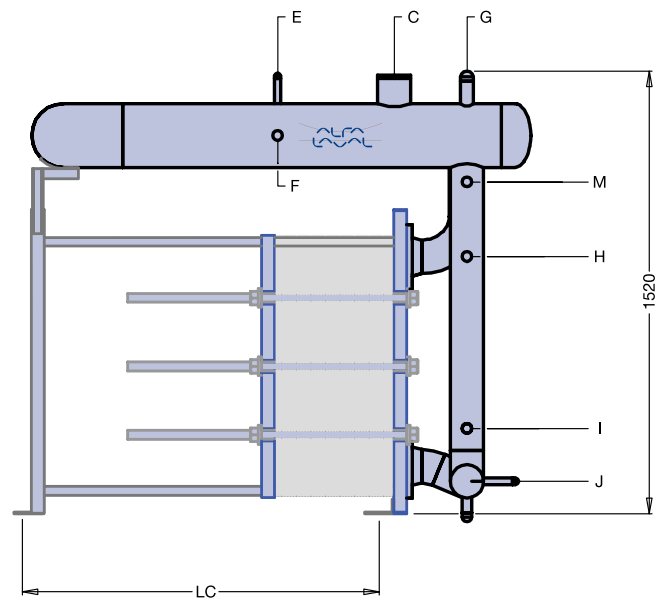
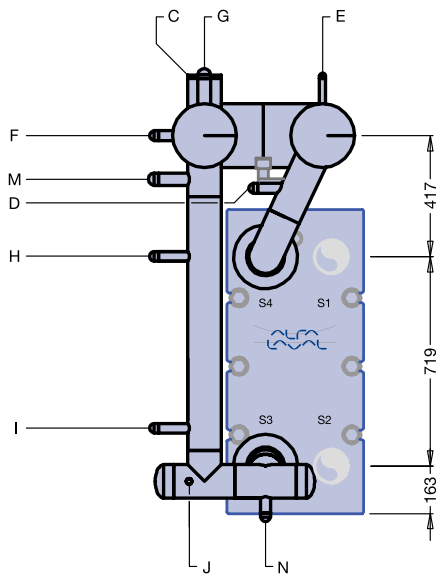

Measurements in mm. Authorized drawing at order .

Nozzle dimensions										
Nozzle	C	D	E	F	G	H	I	J	M	N
Function	Suction gas	Liquid feed	Gauge	Safety relief valve	Liquid level	Liquid level	Liquid level	Oil drain optional	Liquid level high level trip out	Oil drain optional
Dim. [mm]	ø114,3	ø33,7	ø21,3	ø33,7	ø42,4	ø33,7	ø33,7	ø21,3	ø42,4	ø33,7
Type	BW	BW	BW	BW	BW	BW	BW	BW	BW	BW

Main dimensions		
LC Length of carrying bar [mm]	OL Overall length [mm]	LE Efficient length of separation [mm]
900	1475	2130
1200	1775	2830
1600	2175	3530

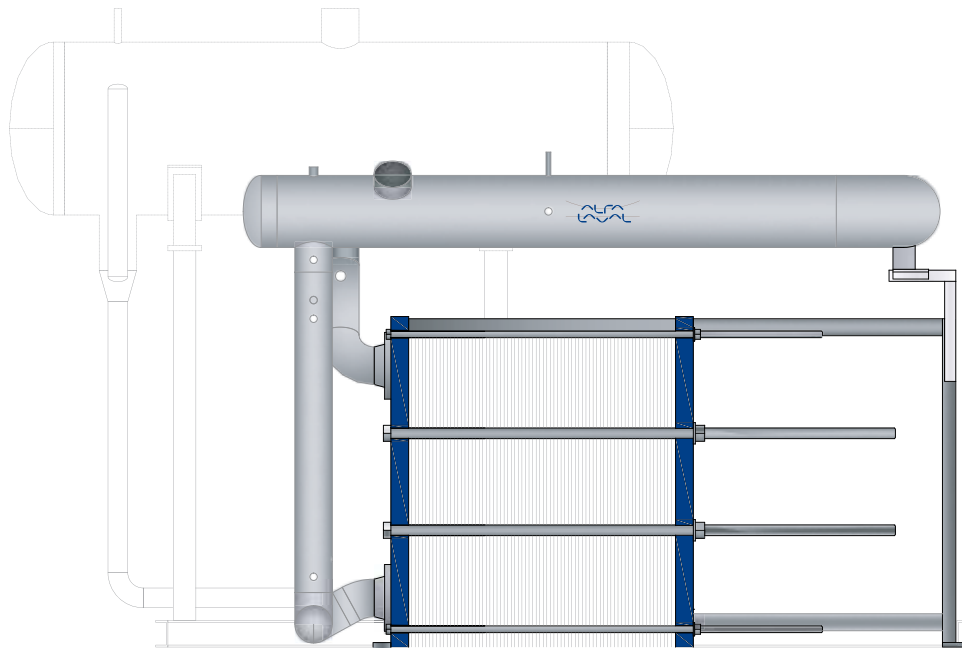

The U-Turn evaporator module design versus traditional separator design.

The design that gives the U-Turn its name

- Compact dimensions
- Shorter height and length – packages can be installed onsite without dismantling
- Effective length (L_{eff}) of U-Turn follows the plate heat exchanger carrying bar length
- Three-point support – the U-Turn separator is supported entirely by the PHE, no additional support is needed.
- Easy maintenance – both sides of PHE fully accessible.
- All ammonia connections access the same side – easy installation
- Integrated oil drain
- Stainless steel – corrosion resistant and no need of surface treatment
- Available in left or right side configuration.

Ready to install

- Short delivery time due to standardization
- Fully functional module from one supplier
- Front plate gives easy access to primary/secondary connections
- CE-stamped and according to PED (Pressure Equipment Directive).

Opening a new chapter in evaporation

- Efficient separation – due to the use of four different separation methods
- Short vertical ammonia driving columns, allowing small temperature approaches and high system efficiency.
- Reduced hold-up/low charge, extremely low refrigerant charges
- Sliding support: allowing thermal expansion, ensuring no thermal tensions build up
- Significant oil pot volume in standard execution enough for manual drain
- Separation based on droplet size 0.15 mm
- Margin for separation is 25% plus one nominal diameter
- Maximum separation gas velocity is restricted to 60% of the re-entrainment velocity, avoiding liquid brought back to the gas flow
- Extra safety margin from 180° U-bend.



How to contact Alfa Laval

Up-to-date Alfa Laval contact details for all countries are always available on our website at www.alfalaval.com.