



GT 50

High-capacity self-cleaning centrifugal separator for fuel oils

The GT 50 is a separator for gas turbine fuel treatment. The GT 50 is the core component in the complete process and system solution for the best possible treatment of these fuels.

Special features of the GT 50 include the Optiflow™ inlet and an optimised disk stack, which ensures the highest separation efficiency of water and solids.

Applications

Purification of mineral oils, especially distillate and light crude oil.

Throughput capacity

The rated maximum capacity for distillate no. 2 is 50 m³/h. The actual maximum recommended capacity depends on the oil to be purified and the performance required (please refer to Alfa Laval capacity tables).

Standard design

The bowl is mounted on a vertical spindle driven by a horizontally mounted motor via a worm gear. The bottom part of the machine forms a housing for the worm gear and also contains the oil bath. Around the bowl is a space formed by the upper part of the frame (which acts as a receptacle for the solids), and the frame hood (which carries the inlet and outlet devices). The design conforms with a number of EC directives, such as the general directives for machinery and centrifuges. The machine is equipped with DIN flange connections.

Standard equipment

Separator with electric motor of controlled torque type. Feed and discharge devices, vibration dampers, standard set of spare parts, set of tools.

Options

Hazardous area execution, vibration switch, temperature sensor for motor winding, and cover interlocking kit.

Auxiliary equipment

Process components, including inlet and outlet pipes, valves



Fig. 1 GT 50

and flexible connections. Programmable logic control unit for functions such as solids discharge control. Starter for electric motor.

Materials

Bowl body and hood	Stainless steel 1.4462, UNS S31803
Lock ring	Steel 25CrMo4, UNS G41300
Distributor	Aluminium bronze CuAl10Fe
Bowl Disc	Stainless steel 1.4401 UNS 31600
Paring chamber cover, level ring	
small lock ring	Brass
Frame, lower and upper parts	Cast grey iron
Frame hood	Cast aluminium alloy
Gaskets and O-rings	Nitrile rubber

Operating principles

Separation takes place inside a rotating bowl. The feed is introduced to the bowl (fig 2) from the top via a stationary inlet pipe (1) and accelerated in the distributor (2) before entering the disc stack (3). The Optiflow™ inlet device in the distributor ensures smooth acceleration of the feed liquid. The separation of the two liquid phases and the solids takes place between the discs. The oil phase moves towards the centre and is discharged via a stationary paring disc (4). The water droplets separated from the feed coalesce at a cylindrical oil/water interface, and the water phase leaves the bowl over the top disc (5) and is taken out by another paring disc (6). The diameter of a gravity disc, forming the inlet to the paring disc chamber, determines the position of the oil/water interface in the bowl and has to be selected according to the density of the light phase. Before oil is fed into the bowl, water is added to form a liquid seal around the periphery of the top disc. The heavy solids are collected at the periphery and ejected from the bowl intermittently at full operating speed. This discharge is achieved by a hydraulic system below the separation space. At preset intervals, this system forces the sliding bowl bottom (7) to drop down, thus opening the solids ports (8) at the periphery. Before discharge, water is added to displace the oil in order to minimize the loss of oil. After discharge, a new water seal is established in the bowl.

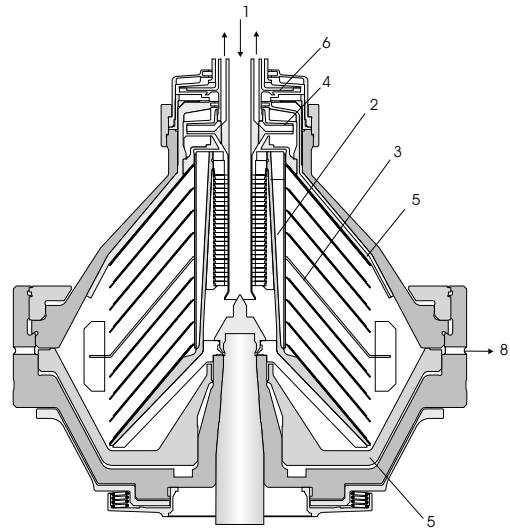

Fig. 2 Typical bowl for a solids-ejecting centrifuge for purification. The details illustrated do not necessarily correspond to the centrifuge described.

Utilities consumption

Electric power	max. 22 kW ¹⁾
Water seal water and discharge water per discharge	17 dm ³
Closing water	170 dm ³ /h

¹⁾ Actual consumption depends mainly on throughput capacity

Dimensions

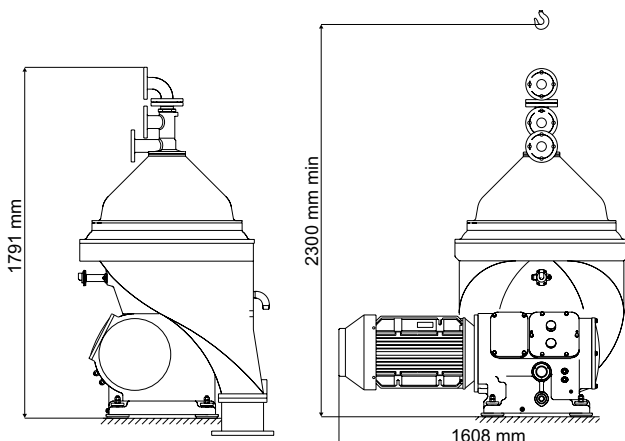

Technical specification

Max throughput capacity	50 m ³ /h ¹⁾
Feed temperature range	0-100 °C
Feed inlet pressure	0 – 350 kPa max.
Light phase density	max. 991 kg/m ³ at 15 °C
Oil outlet pressure	max. 580 kPa ²⁾
Motor power	30 kW
Motor speed synchronous 50/60 Hz	1500/1800 rpm
Starting time	5-7 min
Stopping time with brake	9-15 min
Sound pressure	85 dB(A)
Overhead hoist lifting capacity	1150 kg

¹⁾ Valid for oil viscosity comparable to distillate no. 2. Actual capacity depends on oil density and viscosity, and required degree of separation.

²⁾ Depending mainly on gravity disc diameter.

Shipping data (approximate)

Centrifuge incl. bowl and motor	1571 kg
Motor	285 kg
Bowl	418 kg
Gross weight	1800 kg
Volume	4.56 m ³

How to contact Alfa Laval

Up-to-date Alfa Laval contact details for all countries are always available on our website at www.alfalaval.com