



## FEUX 214

### Solids discharging Nozzle centrifuge

#### Applications

The solids discharging nozzle centrifuge type FEUX 214 is designed specially for separation of baker's and distiller's yeast, fodder yeast and other micro-organisms from fermentation broths. The centrifuge is used to separate, wash and concentrate micro-organisms with normal particle size in the range 5 -15  $\mu\text{m}$ . The content of the suspended solids in the feed is normally in the range 2 - 7.5% DS.

#### Design features

With the patented Alfa Laval self regulating vortex nozzles the concentration of discharged solids phase can be kept at a high and even level irrespective of fluctuations in the feed flow or feed concentration. The centrifuge can thus be operated closer to the clogging point without increasing the risk of clogging.

The Control Panel (optional) handles the control and supervision of the FEUX 214 centrifuge including a cleaning-in-place (CIP) mode. Necessary control valves are optional.

The light and heavy phases are both discharged under pressure which prevents foaming and simplifies installation by eliminating pump systems and improves hygiene. Solids pockets in the bowl guide the solids to the concentrate tubes, preventing accumulation of firmly packed solids and making separation and CIP easier and more effective. Frame hood and solids receptacles are jacketed for circulation of cooling water, which also reduce the noise level. Frame hood is fitted with spray nozzles for washing the outside of the bowl.

#### Standard design

All liquid-wetted parts are made in high-grade stainless steel except the rubber gaskets (EPDM). A special controlled-torque motor eliminates the need for a clutch between the motor and the centrifuge. The bearings are lubricated by an external lubrication circuit. The vertical driving device and bowl spindle is designed as an easily serviced unit. The entire assembly lifts out in one piece. The centrifuge is equipped with sensors for monitoring of bowl speed and vibration level



Fig.1 FEUX 214

#### Options

The centrifuge can be equipped with a gauge switch to prevent the motor from being started unless the centrifuge top part has been properly mounted. Standard motor, 90 and 135kW for frequency converter drive, or control torque motor, 90, 132 and 160kW.

## Operating principles

The feed containing the liquid and the solids is introduced to the rotating centrifuge bowl (fig 2) from the top via a stationary inlet pipe (1), and is accelerated in a distributor (2) before entering the disc stack (3). It is between the discs that the separation takes place. The liquid phase moves through the disc stack towards the centre of the bowl, from where it is pumped out under pressure by means of a built-in paring disc (4). The heavy solids phase is moved outwards by centrifugal force to the solids pockets at the bowl periphery and from there through concentrate tubes (5) and internal vortex nozzles (6) into the paring tube chamber, where the concentrate is skimmed off by the paring tube (7) and discharged under pressure. The bowl can be opened intermittently during production and/or the cleaning cycle for ejections of solids while the machine continues to run at full speed. The pneumatically (8) controlled valve slide (9) under the bowl bottom opens the discharge valves (10) momentarily, permitting the ejections of solids.

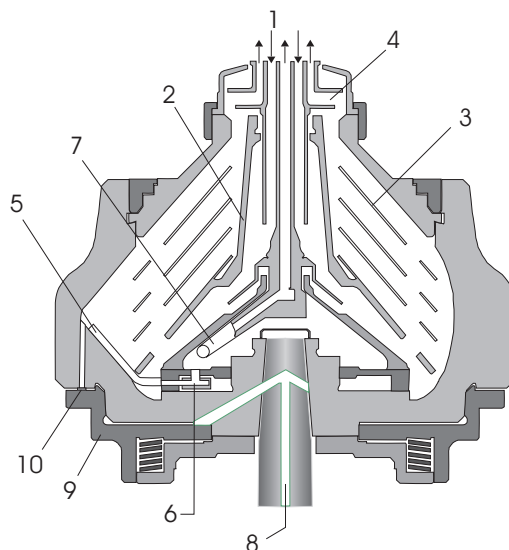

Fig. 2 Typical bowl drawing for a vortex nozzle centrifuge. Drawing details do not necessarily correspond to the centrifuge described.

## Utilities consumption

Electric power	Max 160 kW <sup>1)</sup>
Operating air	25 NI /discharge <sup>2)</sup>
Safety water	10 - 70 m <sup>3</sup> /h <sup>3)</sup>
Flushing liquid	0 - 15 l/discharge <sup>4)</sup>
Cooling liquid	500 l/h <sup>6)</sup>

<sup>1)</sup> Actual consumption depends on exact throughput capacity, centrifugate & concentrate flowrate and applied back pressure.

<sup>2)</sup> Instrument quality, 500 - 600 kPa. Actual consumption depends on CIP-discharge frequency.

<sup>3)</sup> The bowl should be filled with liquid at start, stop and normal operation. In case process liquid is not available, safety water should be used. Minimum flow shall be 10% above nozzle flow.

<sup>4)</sup> 100 - 600 kPa, 300 kPa suggested. Momentary flowrate at suggested pressure up to 800 l/h. Used only during CIP.

<sup>6)</sup> Data valid for 50 kPa. Max. pressure 100 kPa.

## Shipping data (approximate)

Centrifuge with bowl and motor	
Net weight:	4670 kg
Gross weight:	4960 kg
Volume:	8.0 m <sup>3</sup>

## Dimensions

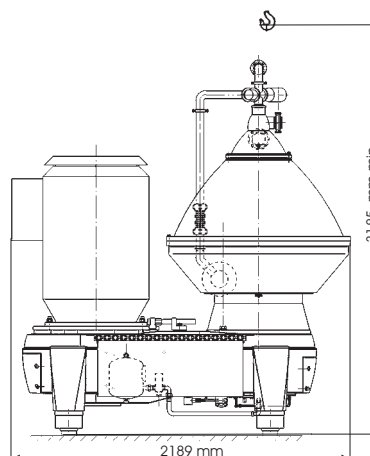
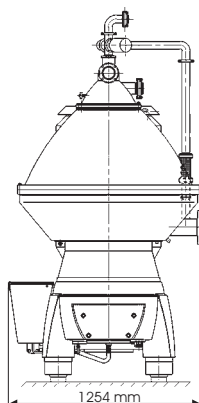

## Technical specification

Max. throughput capacity	100 m <sup>3</sup> /h <sup>1)</sup>
Max. nozzle flow	30 m <sup>3</sup> /h <sup>2)</sup>
Feed temperature range	0 - 100 °C
Feed inlet pressure required	Max. 100 kPa <sup>3)</sup>
Centrifugate outlet pressure available	500 kPa <sup>4)</sup>
Concentrate outlet pressure available	600 kPa
Installed motor power	90/132/135/160 kW
Noise level	78.5 dB(A)

<sup>1)</sup> Actual consumption depends on exact throughput capacity, centrifugate & concentrate flowrate and applied back pressure.

<sup>2)</sup> Wet Solids

<sup>3)</sup> Data valid for water at feed flowrates up to 100 m<sup>3</sup>/h and outlet pressure 400 kPa.

<sup>4)</sup> Data valid for a centrifugate flowrate flow of 80 m<sup>3</sup>/h

## How to contact Alfa Laval

Contact details for all countries are continually updated on our website. Please visit [www.alfalaval.com](http://www.alfalaval.com) to access the information direct.